

# Laminex™ Panels for Partitions

## Laminex™ Panels for Partitions Standard Range Technical Data Sheet

Laminex™ Panels for Partitions – Standard Range, with Protec+™ Antimicrobial surface performance, is strong, durable and moisture resistant, making it suitable for a wide variety of uses.

### Applications

- Healthcare: Hospitals, doctors surgeries, laboratory environments, laboratory furniture
- Commercial: Office furniture, reception counters
- Hospitality: Lobby counters, bars, hotels
- Public and Leisure spaces: Gymnasiums, swimming pools, schools, shopping centres, sanitary facilities, prisons, universities, sports and recreational centres, libraries.

### When Specifying

Surfacing shall be Laminex™ Panels for Partitions as distributed by Laminex New Zealand™. Colours and/or patterns shall be..... in finish .....



Laminex™ Panels for Partitions with Protec+ contains antifungal and antibacterial resistant properties which do not wash off or leach out of the surface. It is safe for use in food preparation and processing activities and can be in direct contact with food, provided that good hygiene practices are followed.

| Product Characteristics |   |
|-------------------------|---|
| Finish                  | Natural   |
| Thickness               | 13mm  |
| Decorated               | Double Sided  |
| Core                    | Black   |
| Panel Dimension         | 3660 x1830mm  |
| Applications            | Shower & Toilet Cubicles, Office Worktops, Interior Wall Cladding, Lockers, Kitchen Benchtops & Cabinetry, Educational Furniture, Durable Furniture |

| Typical Properties               |                    |                     |                |
|----------------------------------|--------------------|---------------------|----------------|
| Property                         | Unit               | Material Properties | Standard*      |
| <b>Physical Properties</b>       |                    |                     |                |
| Specific Gravity (minimum)       | kg/m <sup>2</sup>  | 1420                | EN 438-4       |
| Weight 13 mm thickness           | kg/m <sup>2</sup>  | 18.5                |                |
| <b>Fire Properties</b>           |                    |                     |                |
| Fire Hazard Indices              | Range              |                     | AS/NZS 1530.3  |
| Ignitability                     | 0-20               | 10                  |                |
| Spread of Flame                  | 0-10               | 0                   |                |
| Heat Evolved                     | 0-10               | 2                   |                |
| Smoke Developed                  | 0-10               | 4                   |                |
| <b>Cone Calorimeter</b>          |                    |                     |                |
| Group Number                     | 1-3                | 3                   | ISO5660.1-2015 |
| Average Specific Extinction Area | m <sup>2</sup> /kg | 45.5                |                |

\*AS/NZS 2924.1: compact general purpose standard (CGS) material type.

# Laminex™ Panels for Partitions

## Inspection Requirements

Laminex™ Panels for Partitions has a thickness of 2mm and greater. Manufacturing specifications of the Laminex™ Panels for Partitions references standard EN 438-4.

| General Inspection Requirements                               |   |
|---|---|
| Viewing Distance  | Approximately 150cm   |
| Light Conditions  | Intensity 800–1000 lux over the whole area  |
| Light Type  | Overhead white fluorescent lights, of colour temperature approximately 5000K  |
| Inspection Requirements of Colour, Pattern and Surface Finish |   |
| Colour and Pattern  | When inspected in daylight or D65 standard illuminant, and under tungsten illuminant, there shall be no significant difference between the corresponding colour or pattern reference sample held by the supplier and the specimen under test. |
| Surface Finish  | When inspected at different viewing angles, there shall be no significant difference between corresponding surface-finish reference sample held by the supplier and the specimen under test.  |
| Visual Inspection   |   |
| Dirt, spots and similar                                       | Max. 1 mm <sup>2</sup> /m <sup>2</sup> and is proportional to the sheet size. Total admissible area of contamination may be surface defects concentrated in one spot or dispersed over an unlimited amount of smaller defects.                |
| Fibres, hairs and scratches                                   | Max. 10 mm/m <sup>2</sup> and proportional to the sheet size. Total admissible area of contamination may be concentrated in one spot or dispersed over an unlimited amount of smaller defects.  |
| Edge quality: chipping  | Max. 3mm/side   |

| Dimensional Tolerances              |   |             |  |
|-------------------------------------|---|-------------|--|
| Property                            | Test method<br>(EN 438-2: 2005, clause no.) | Unit        | Values   |
| Thickness                           | 5   | mm (max.)   | $3.0 \leq t < 5.0 \text{ mm} : \pm 0.30 \text{ mm}$<br>$5.0 \leq t < 8.0 \text{ mm} : \pm 0.40 \text{ mm}$<br>$8.0 \leq t < 12.0 \text{ mm} : \pm 0.50 \text{ mm}$<br>$12.0 \leq t < 16.0 \text{ mm} : \pm 0.60 \text{ mm}$<br>$16.0 \leq t < 20.0 \text{ mm} : \pm 0.70 \text{ mm}$<br>$20.0 \leq t < 25.0 \text{ mm} : \pm 0.80 \text{ mm}$<br>$25.0 \text{ mm} \leq t : \text{to be agreed between supplier and customer.}$<br><i>(t = nominal thickness)</i> |
| Flatness <sup>a)</sup>              | 9   | mm/m (max.) | $2.0 \leq t < 6.0 \text{ mm} : 8.0 \text{ mm/m}$<br>$6.0 \leq t < 10.0 \text{ mm} : 5.0 \text{ mm/m}$<br>$10.0 \text{ mm} \geq t : 3.0 \text{ mm/m}$<br><i>(t = nominal thickness)</i>   |
| Length and Width <sup>b)</sup>      | 6   | mm          | - 0/+ 10 mm  |
| Straightness of edges <sup>b)</sup> | 7   | mm/m (max.) | 1.5 mm/m   |
| Squareness <sup>b)</sup>            | 8   | mm/m (max.) | 1.5 mm/m   |

a) Provided the laminates are stored in the manner and conditions recommended by the manufacturer, they shall comply with the flatness requirements specified in the above table when measured in accordance with EN 438-2, Clause 9. The flatness values specified in the above table apply to laminates with two decorative faces. Limits for laminates with one face sanded shall be agreed between supplier and customer.

b) Tolerances for cut-to-size panels shall be agreed between supplier and customer.

# Laminex™ Panels for Partitions

| Alphabetical Classification System                           |   |  |   |                                     |   |        |
|--|---|--|---|-------------------------------------|---|--------|
| First letter   | C (Compact Grade)                           |  |   |                                     |   |        |
| Second letter  | G (General purpose)                         |  |   |                                     |   |        |
| Third letter   | S (Standard Grade)                          |  |   |                                     |   |        |
| General Requirements   |   |  |   |                                     |   |        |
| Property   | Test method<br>(EN 438-2: 2005, clause no.) | Property<br>or attribute                         | Unit<br>(min. or max.)  | Values<br>CGS                       |   |        |
| Resistance to Surface Wear                                   | 10  | Wear Resistance                                  | Revolutions (min.)<br>Initial point<br>Wear value   | 150<br>350                          |   |        |
| Resistance to Impact by<br>Large Diameter Ball <sup>c)</sup> | 21  | Drop<br>Height                                   | mm (min.)<br>$2 \leq t < 6$<br>$6 \leq t$<br>( <i>t = nominal thickness</i> )                                 | 1400<br>1800                        |   |        |
| Resistance to Scratching <sup>d)</sup>                       | 25  | Force  | Rating (min.)<br>Smooth finishes<br>Textured finishes   | 2 = 1N<br>3 = 2N                    |   |        |
| Resistance to Dry Heat (180°C)                               | 16  | Appearance                                       | Rating (min.)<br>Gloss finish<br>Other finishes   | 3<br>4                              |   |        |
| Resistance to Wet Heat (100°C)                               | EN12721                                     | Appearance                                       | Rating (min.)<br>Other finishes   | 4                                   |   |        |
| Resistance to Immersion in Boiling<br>Water                  | 12  | Mass increase                                    | % (max.)  | 5.0                                 |   |        |
|  |   | Thickness  | $2 \text{ mm} \leq t < 5 \text{ mm}$  | 2.0                                 |   |        |
|  |   | Increase   | $t \geq 5 \text{ mm}$   | 6.0                                 |   |        |
|  |   | Appearance                                       | % (max.)<br>$2 \text{ mm} \leq t < 5 \text{ mm}$<br>$t \geq 5 \text{ mm}$<br>( <i>t = nominal thickness</i> ) | 2.0                                 |   |        |
|  |   |  | Rating (min.)<br>Gloss finish<br>Other finishes   | 3<br>4                              |   |        |
|  |   | Dimensional Stability at<br>Elevated Temperature | 17  | Cumulative<br>Dimensional<br>Change | % (max)<br>$2 \text{ mm} \leq t < 5 \text{ mm L}^{\text{a)}$<br>$2 \text{ mm} \leq t < 5 \text{ mm T}^{\text{b)}$<br>$t \geq 5 \text{ mm L}$<br>$t \geq 5 \text{ mm T}$<br>( <i>t = nominal thickness</i> ) | 4      |
|  |   | Resistance to Staining                           | 26  | Appearance                          | Rating (min.)<br>Groups 1&2<br>Group 3  | 5<br>4 |
| Lightfastness (Xenon Arc)                                    | 27  | Contrast   | Grey scale rating   | 4 - 5                               |   |        |
| Resistance to Water Vapour                                   | 14  | Appearance                                       | Rating (min.)<br>Other finishes   | 4                                   |   |        |
| Resistance to Cigarette Burns                                | 30  | Appearance                                       | Rating (min.)   | 3                                   |   |        |
| Resistance to Crazing  | 24  | Appearance                                       | Grade (min.)<br>Smooth finish   | 3 - 4                               |   |        |
| Flexural Modulus   | EN ISO 178                                  | Stress   | Mpa (min.)  | 9000                                |   |        |
| Flexural Strength  | EN ISO 178                                  | Stress   | Mpa (min.)  | 80                                  |   |        |
| Tensile Strength   | EN ISO 527                                  | Stress   | Mpa (min.)  | 60                                  |   |        |
| Density  | EN ISO 1183                                 | Density  | kg/m <sup>3</sup> (min.)  | 1350                                |   |        |

# Laminex™ Panels for Partitions

| General Requirements cont.                            |  |  |  |   |
|---|--|--|--|---|
| Antibacterial Activity and Efficacy                   | JISZ2801:2000<br>Referred by ISO 22196 |  |  | Compliance  |
| Antifungal  | ASTMG21-09                             |  |  | Inhibits growth on the surface according to ASTM G21-09   |
| Compliance with the Demands of Food Contact Materials |  |  |  | Official collection of testing methods according to Rules and Regulations of the EC and EU community. |

a) L = in the longitudinal (or machine) direction of the fibrous sheet material (normally the direction of the longest dimension of the laminate).  
 b) T = in the cross-longitudinal (cross-machine) direction of the fibrous sheet material (at right angles to direction L).  
 c) When tested to specified drop height the diameter of the indent shall not exceed 10mm  
 d) Minimum IN for darker colours.

## Interpretation of ratings

### All ratings unless specified:

5. No visible change
4. Slight change of gloss and/or colour only visible at certain viewing angles
3. Moderate marked change of gloss and/or colour
2. Marked change of gloss and/or colour
1. Surface distortion and/or blistering

### Resistance to moisture:

4. Slight change of gloss/colour or slight edge swell or hairline edge cracks

### Cigarette burn:

5. No visible change
4. Slight change of gloss and/or colour only visible at certain viewing angles and/or slight brown stain
3. Moderate marked change of gloss and/or moderate brown stain
2. Severe brown mark, but no destruction of the surface
1. Surface distortion and/or blistering

### Crazing:

5. Surface and edges unchanged from "as received" condition
4. Surface unchanged, with slight hairline edge cracks visible to the naked eye
3. Surface cracks visible to the naked eye, and/or moderate edge cracks
2. Moderate surface cracks, and/or delamination
1. Severe surface cracks, and/or delamination

Laminex New Zealand™ declares that the mentioned product will meet the above specifications when determined according to the given standards.

# Laminex™ Panels for Partitions

## Staining Agents and Test Conditions

| Staining Agent  | Test Conditions                             | Contact Time |
|---|---|--------------|
| <b>Group 1</b>  |   |              |
| *Acetone  | Apply staining agent at ambient temperature | 16 hours     |
| Other organic solvents  |   |              |
| Toothpaste  |   |              |
| Hand cream  |   |              |
| Urine   |   |              |
| Alcoholic beverages   |   |              |
| Natural fruit and vegetable juices  |   |              |
| Lemonade and fruit drinks   |   |              |
| Meat and sausages   |   |              |
| Animal and vegetable fats and oils  |   |              |
| Water   |   |              |
| Yeast suspension in water   |   |              |
| Salt (NaCl) solutions   |   |              |
| Mustard   |   |              |
| Lyes, soap solutions  |   |              |
| Cleaning solution consisting of: <ul style="list-style-type: none"> <li>• 23% dodecylbenzene sulfonate</li> <li>• 10% alkyl aryl polyglycol ether</li> <li>• 67% water</li> </ul> |   |              |
| Commercial disinfectants  |   |              |
| Stain or paint based removers based on organic solvents   |   |              |
| Citric acid (10% solution)  |   |              |
| <b>Group 2</b>  |   |              |
| Coffee (120g of coffee per litre of water)  | Apply staining agent at approximately 80°C  | 16 hours     |
| Black tea (9g of tea per litre of water)  |   |              |
| Milk (all types)  |   |              |
| White vinegar   | Apply staining agent at ambient temperature | 16 hours     |
| Alkaline-based cleaning agents (to 10% concentration with water)  |   |              |
| Hydrogen peroxide (3% solution)   |   |              |
| Ammonia (10% solution of commercial concentrate)  |   |              |
| Nail varnish  |   |              |
| Nail varnish remover  |   |              |
| Lipstic   |   |              |
| Water colours   |   |              |
| Laundry marking inks  |   |              |
| Ballpoint inks  |   |              |

# Laminex™ Panels for Partitions

| Staining Agent   | Test Conditions                             | Contact Time |
|--|---|--------------|
| <b>Group 3</b>   |   |              |
| Sodium hydroxide (25% solution)                                      | Apply staining agent at ambient temperature | 10 minutes   |
| Hydrogen peroxide (30% solution)                                     |   |              |
| Concentrated vinegar (30% acetic acid)                               |   |              |
| Bleaching agents and sanitary cleaners containing them               |   |              |
| Hydrochloric acid based cleaning agents ( $\leq$ 3% HCl)             |   |              |
| Acid-based metal cleaners  |   |              |
| Mercurochrome (2,7-diabrom-4-hydroxymecurifluoresein, disodium salt) |   |              |
| Shoe polish  |   |              |
| Hair colouring and bleaching agents                                  |   |              |
| Iodine   |   |              |
| Boric acid   |   |              |
| Lacquers and adhesives (except fast curing materials)                |   |              |
| Amidosulfonic acid descaling agents (< 10% solution)                 |   |              |

*1) Some commercial cleaning agents contain acids and alkalis in concentrations stronger than those shown in Group 3, and can cause surface marking or damage. Any spillage of such materials must be washed off immediately.*

# Laminex™ Panels for Partitions

## General Knowledge

- As Laminex™ Panels for Partitions are made of approximately 70% kraft paper, it is somehow similar to wood behaviour. Therefore Laminex™ Panels for Partitions will be affected by moisture.

The effect of the surrounding temperature will not affect the expansion and contraction of the panels but it will be influenced by the moisture content within the environment.

Hence if the temperature and relative humidity is high in the environment, it will speed up the expansion process and the opposite will cause contraction in the panels.

Usually thinner panels will expand faster than thicker panels as moisture penetration is faster for thinner panels in high moisture content environment.

Maximum expansion or contraction of Laminex™ Panels for Partitions panels is approximately 2.5mm/m in length and it is not dependable on the panel thickness, hence always leave a sufficient gap between the two adjoining panels and near the edges of the walls as shown below.

Laminex™ Panels for Partitions equilibrium condition is usually at 25°C with relative humidity of about 50%.

- When subjected to moisture, Laminex™ Panels for Partitions will expand more in the cross sectional direction than the longitudinal direction. The ratio of expansion rate is about 1:2. This means that the cross sectional direction will expand at about 2 times more than the longitudinal direction.
- If there is any chemical spillage on the surface, clean it as soon as possible as certain chemicals will evaporate thus becoming more concentrated. Do not leave spilled chemicals on the surface overnight or over a prolonged period as it may damage the surface.

When cleaning the surface, use a soft damp cloth with non-abrasive type of cleaning agent.

- Do not use strong acid or alkaline cleaning agents as they may stain or damage the worktop surface.
- Any residual adhesive, paint and dyes will need to be removed quickly to avoid permanent staining on the surface. Always use suitable type of solvent or mild household cleaning liquid to clean away these residues as required, use a non-abrasive cloth to clean it.
- Common alcohol based disinfectants or acetone can be used to disinfect the surface.
- Avoid using abrasive materials or sharp objects sliding over the surface as it can scratch the decorative surface.
- Although the surface can resist 180°C dry heat temperature, it is not advisable to leave prolonged high temperature objects on the surface. Always use insulated hot pads to put the hot objects on instead of placing it directly onto the surface.

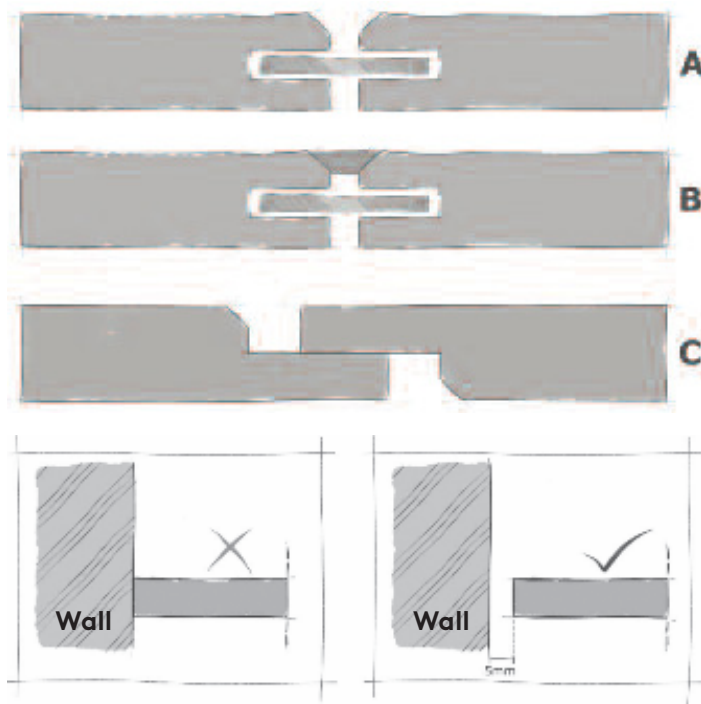

## Site Work Notes

### Fabrication

Laminex™ Panels for Partitions can be cut, drilled and machined with standard woodworking equipment fitted with tungsten carbide edges.

Select brackets, hinges screws and fastening equipment etc. to suit the environment of the installation. Higher corrosive atmospheres such as salty and chlorine environments may be more corrosive than inland dryer climates. Surface mounted objects should be secured using self-tapping screws, thread cutting screws or threaded brass inserts in pre-drilled holes.

Laminex™ Panels for Partitions is a very hard material, use high quality screws and predrill pilot hole 0.5mm smaller than screw gauge as a guide, or follow as recommended by screw manufacturer, caution not to over tighten to avoid snapping screw.

# Laminex™ Panels for Partitions

## Screw location

Screws should be carefully positioned to prevent splintering and breakout – no closer than 20mm to an edge. If screwing into an edge it is not recommended to place it closer than 75mm from end of a panel. (In general screws into the edges should be avoided). Through fixing is recommended for 6mm thick panels.

Metal brackets are recommended for securing the panels together.

Mitring of edges should be avoided as they are vulnerable to damage.

A chamfered edge or crescent shaped edge will avoid edge chipping or flaking.

Standard tools for hardwood can be used for machining or processing such as sawing, drilling and routing.

Neither the surface nor the sawn edges need to be protected or sealed. Panels will present a distinctive black edge.

Ensure that pooling of water on the surfaces of Laminex™ Panels for Partitions cannot occur and allow sufficient ventilation and drainage in enclosed spaces such as cabinets.

## Cutting Doors Or Panels

To minimise warping of doors and panels it is recommended that panels must be cut with the long edge parallel to the length of the sheet. Warping occurs when both sides of a door or panel are not exposed to the same humidity level. The longer a sheet is, the larger the impact of warping will be. Ensure as far as possible that ambient conditions are the same on each side of a panel as it is important both sides gain and lose moisture at the same rate.

Where panels are mounted on a wall or enclosed in a cabinet for example, ensure adequate ventilation to ensure temperature and humidity at the back of the panel is essentially the same as the front. Fixing centres should be sufficiently close to prevent excessive freedom of movement. Cubical doors for example greater than 1500mm high should have 3 hinges as a minimum guide.

*Note: An exception is when Laminex™ Panels for Partitions is used for sash doors. The panels have to be cut out of the width of the basic sheets instead of the length. If a sash door is cut out of the length of a sheet the horizontal bow will interfere with the sliding action of the door. It is preferable to have a vertical bow for this application and cutting out of the width of the basic sheet is recommended. If black core is scorched due to dull blades or jamming when cutting, the edge can be restored by taking a fine cut or sanding back to restore the black edge.*

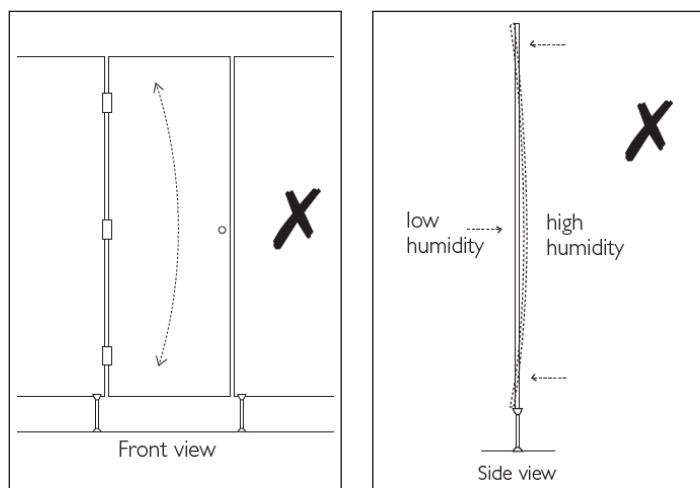

*Incorrect: door cut out of width of a sheet, warpage vertically*

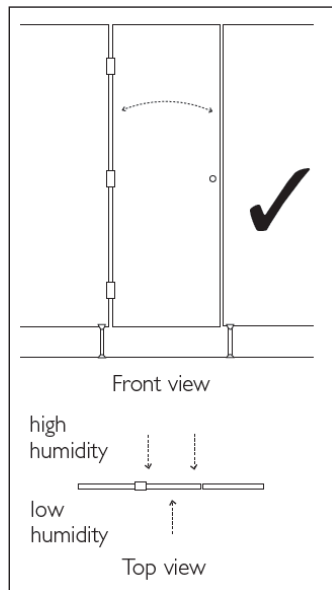

*Correct: door cut out of length of a sheet, warpage horizontally*

## Maintaining clean fresh looking black core edges

The black core is a visual feature of Laminex™ Panels for Partitions. This can be enhanced after machining and maintained by use of wet and dry sand paper. To prepare and smooth the edge use extra fine (400grit) then burnish smooth using Ultra fine 2000grit lubricated with linseed or tung oil. When complete wipe on linseed or tung oil to maintain surface. To maintain edges over time clean down and apply oil. Caution when preparing the edge do not damage the decorative surface.

## Processing

### Sawing

It is strongly recommended that all sawing operations for Laminex™ Panels for Partitions to be done with stationary circular saw to achieve optimum finishing effect and always use some trial panels to test first before actual operation. Always make sure that the decorative surface facing upwards to prevent damage chipping edges on the surface.

A carbide or diamond tipped saw blade should be used to saw the panels.

The height setting of the saw blade should be approximately 30-40mm above the decorative surface. The image below illustrates the correct setting of the saw blade so as to avoid chipping saw edges.

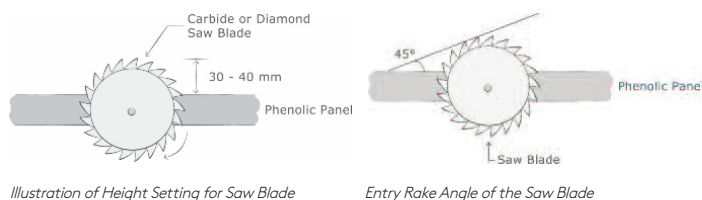

*Illustration of Height Setting for Saw Blade*

*Entry Rake Angle of the Saw Blade*

Entry rake angle of about 45° will give the panels nice and straight sawn edges as shown below.

The saw blade must always be sharp and if necessary, remove it to sharpen or change to a new one before continuing the sawing operation. All sharp sawn edges should be removed with fine sand paper or router to achieve good and smooth finishing effect.



# Laminex™ Panels for Partitions

## Recommended Sawing Operation for Laminex™ Panels for Partitions

| Saw Blade | No. of Saw Teeth | No. of Revolutions for Saw Machine (rev/min) | Blade Thickness (mm) | Height Setting (mm) | Feeding Speed (m/min) |
|-----------|------------------|--|----------------------|---------------------|-----------------------|
| 300       | 72               | 6000   | 3.5                  | 30                  | 7-22                  |
| 400       | 96               | 4000   | 4.8                  | 40                  |                       |

### Routering

Routering of edges require hard metal or diamond cutter at slow speed to achieve good finishing without burn marks on the phenolic core surface.

This operation can be done with either a CNC machine or manual operated routering cutter. Depending on the type of router shapes, the cutter bits below can achieve the desired effect.

### Types of Router Bits for Different Types of Edge Finishing

| Edge Finishing | Type of Bit          |
|----------------|----------------------|
| Bevelling      | Straight and Slanted |
| Rounded        | Hollow or Round      |
| Groove         | Diamond Groove       |

For CNC operation, please follow the machine manufacturer instructions. For manual operated routering, the table below shows essential information for the operation.

### Manual Operated Routering Operation

| Bit Diameter (mm) | No. of Revolutions (rev/min) | Speed (m/s) | Feeding Speed (m/min) |
|-------------------|------------------------------|-------------|-----------------------|
| 20                | 18000                        | 20          | 5                     |
| 25                | 24000                        | 30          |                       |

### Drilling

The most suitable drills used on Laminex™ Panels for Partitions are those designed for plastic sheet materials. These drills have a point angle of 60°C - 80°C instead of the normal 120°C for drilling metal. To avoid breakout on the reverse side, the feed speed of the drill head and the pressure applied should be gradually reduced approaching the point of breakthrough. Working on a firm underlay, such as plywood or chipboard, will also reduce the risk of breakout.

For blind boring into the face, the depth of the hole should be such that at least 2mm of material remains between the bottom of the hole and the other side of the sheet.

TCT lip and Sur drills will produce clean flat bottom holes, with less risk of point penetration on the reverse side. This will allow maximum depth of material for fixing.

Laminex™ Panels for Partitions less than 10mm thick are not considered suitable for blind fixing.

When drilling parallel to the surface (edge drilling) at least 3mm of material must remain on either side of the hole.

Threaded holes using engineers taps, thread cutting screws or threaded brass inserts may also be used.

HSS drill, top angle 60°C-80°C. Panels should be drilled with support sheets.

| Section               | 5mm           | 8mm          | 10mm         |
|-----------------------|---------------|--------------|--------------|
| Number of Revolutions | 3,000         | 2,000        | 1,500        |
| Start                 | 60-120 mm/min | 40-80 mm/min | 30-60 mm/min |

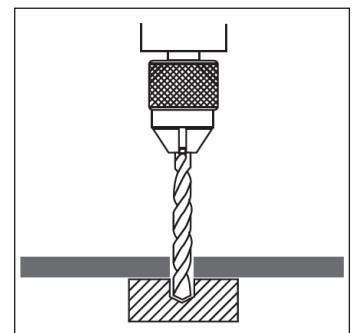
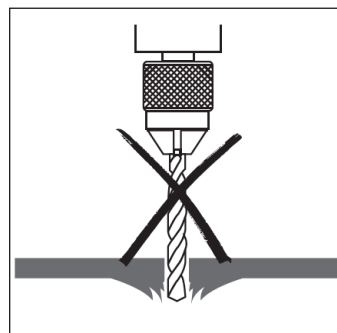

# Laminex™ Panels for Partitions

## Intersections

### T-Intersection

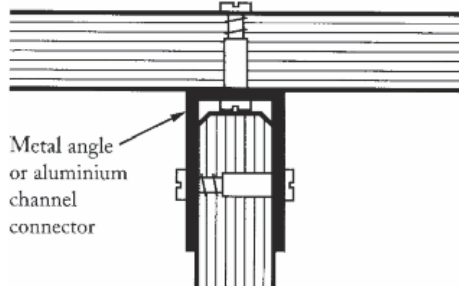

### Edge with Sliding Doors

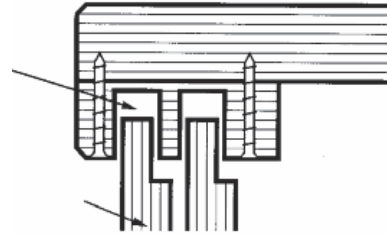

### External Corner

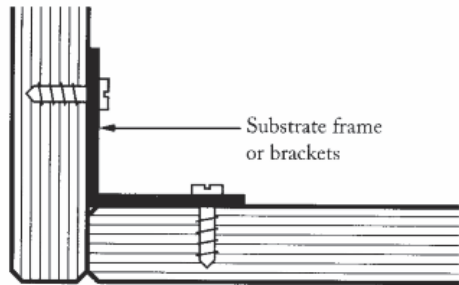

## Splashbacks

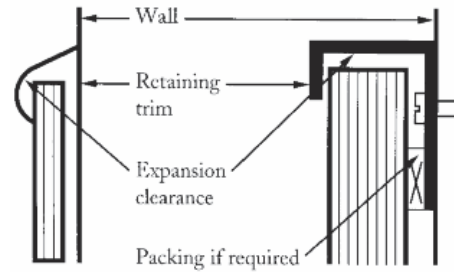

### Internal Corner

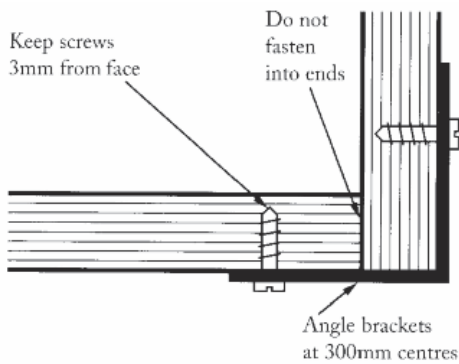

## Joints

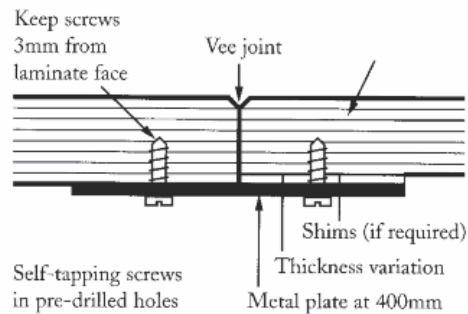

## Edges & Nosings

### Standard Edge

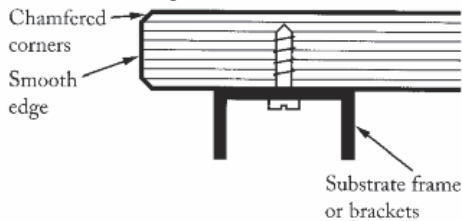

### Built-Up Edge



## Pass-through Objects

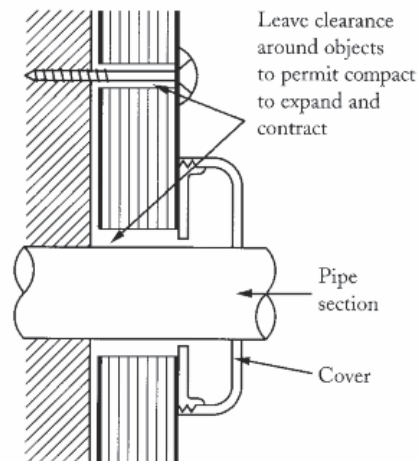

# Laminex™ Panels for Partitions

## Gluing

1. Laminex™ Panels for Partitions can be glued to other types of materials with either epoxy or polyurethane adhesives. Both types of adhesives usage is approximately 100-250 g/m<sup>2</sup> with applied pressure of at least 0.2 N/mm<sup>2</sup> for about 4-8 hours at 20°C to ensure proper adhesion to the joining parts.
2. It is also advisable to use mechanical fastening to provide sufficient press pressure to the glued area to ensure that both components are properly intact after the adhesive is fully cured, for this please refer to the usage and instruction guidelines of the glue manufacturer.
3. If gluing 2 pieces of compact or strips together, it is important to ensure that both panels should be in the same directional grain as illustrated in the Figure 6

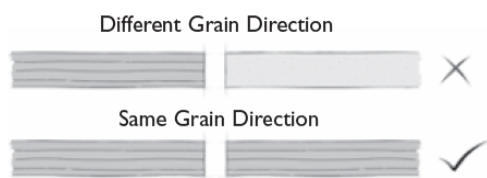

4. It is advisable to pre condition or 'climatise' the panels and strips to the same environment condition before gluing them together.
5. Remove any grease, dirt or dust on the surface. Always use fine sand paper to slightly roughen the surface to ensure good and proper adhesion of the glue.
6. It is very important to check with the adhesive manufacturer the correct method of application
7. Ensure that the adhesive has a similar or better expansion and contraction rate as the compact. Always remember that the maximum expansion and contraction is approximately 2.5mm/m length.

## Care And Cleaning

The non-porous surface is easy to clean. For general cleaning, household cleaners, water or soap are highly recommended. Do not use abrasive or polishing materials. Both the decorative surface and homogenous core of Laminex™ Panels for Partitions are impervious and resistant to most commonly used cleaning agents and disinfectants. The surfaces of Laminex™ Panels for Partitions furniture can be easily cleaned with a dry or damp cloth and, if necessary, a mild household cleaner. Wipe damp surfaces with an absorbent cloth. High pressure water cleaning or steam cleaning of panels is not recommended. Maintain a clean work surface so as not to compromise the antibacterial and antifungal properties.

### Removing Severe Soiling

Severely dirty surfaces or areas where normal soiling\* has built up over a long period of time are easy to clean with hot water and an interior detergent- or soap-based cleaning agent, applied with a sponge or soft nylon brush. Apply the diluted cleaning agent to the surface and leave it to soak for a while. Then rinse off with clean water and dry with an absorbent cloth.

\*Dust, dirt, coffee, tea, fruit juice, food residues, grease, soap residues, lime scale, water-soluble paints and adhesives.

### Removing Special Staining

Solvent-based varnishes and adhesives (nail varnish, rubber stamp ink, and aerosol paint) should be removed with organic solvents such as acetone, white spirit, turpentine or petroleum. Remove wax from candles or crayons immediately with water and a mild household cleaning agent. Dried wax stains may first have to be scraped off with a wooden or plastic spatula and the remainder removed with an organic solvent. Two part paint or adhesive, synthetic resin and the like should be removed immediately with water or an organic solvent. Once these products have set, they cannot be removed without damaging the surface. Lime scale can be removed with acidic cleaning agents containing approximately 10% acetic acid or citric acid.

The manufacturer's instructions must be strictly followed. Rinse surfaces and edges very thoroughly! Paint, varnish, ink, shoe polish, lipstick, tar and other soluble (but strong) stains can be removed with organic solvents such as acetone, white spirit, turpentine or petroleum spirit.

Rub silicone off dry or use silicone remover. Both the decorative surface and core of Laminex™ Panels for Partitions are highly resistant to most commonly-used disinfectants. Long term use of chlorine bleach cleaners, acidic or alkaline cleaners can cause colour and appearance changes to the surface.

# Laminex™ Panels for Partitions

## Storage & Handling Conditions



1. Laminex™ Panels for Partitions sheets are heavy. Ensure you use the right forklift length for the laminate stacking height and sheet size. Don't overload the forklift.

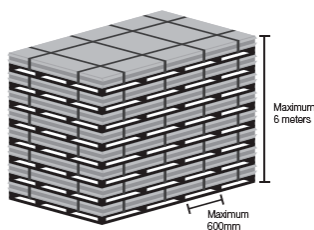

2. During storage the sheets must be parallel to the ground and aligned with each other on bearers that are evenly spaced on a flat surface. Maximum space between bearers is 600mm. Protect the sheet corners.

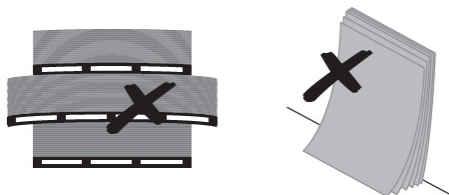

3. Do not stand the sheets against a wall vertically. Make sure there are no cavities between the sheets.

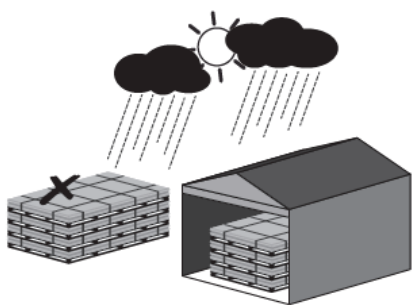

4. Store in a dry, sheltered area. Do not leave the sheets inside the pallet in the rain or direct sunlight.

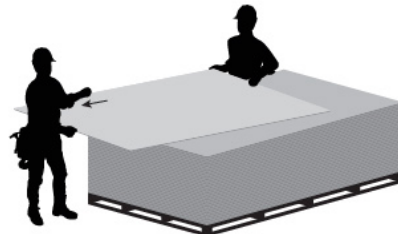

5. Sheets must be carried by at least 2 people, or if using a forklift or suction lift, move sheets gently to avoid damage.

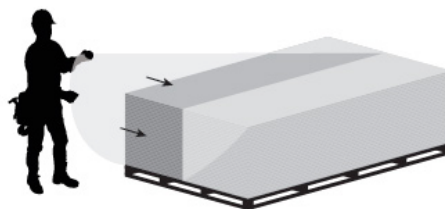

6. Protect laminates with a moisture impermeable cover. Do not stack bundles of different size on top of each other. If laminates are removed from the pallet for storage, it's recommended that the plastic film is removed to ensure even moisture absorption on both sides of the panel.