

# seratone®

Technical Installation Manual



seratone®  
AQUA

seratone®  
AQUA PLUS™

**Laminex®**  
NEW ZEALAND

# Contents

<b>1</b>	<b>Scope and interpretation</b>	<b>02</b>
1.1	Purpose of this manual	02
1.2	Identification	02
1.3	Compliance	02
1.3.1	Seratone® AQUA	02
1.3.2	Seratone® AQUA PLUS™	03
1.4	Make sure your information is up to date	03
<b>2</b>	<b>General product and description</b>	<b>04</b>
2.1	Seratone® AQUA and Seratone® AQUA PLUS™ uses	04
2.2	Seratone® range	04
<b>3</b>	<b>Material properties</b>	<b>05</b>
3.1	Seratone® AQUA product details	05
3.2	Seratone® AQUA PLUS™ product details	06
<b>4</b>	<b>Durability</b>	<b>08</b>
4.1	Limitations	08
4.2	Handling and storage	08
4.3	Cleaning	08
4.4	Durability conditions	09
4.5	Moisture content	09
4.6	Permeability	09
4.7	Effects of heat	09
4.8	Fire properties	09
<b>5</b>	<b>Design considerations</b>	<b>10</b>
5.1	Design considerations	10
5.1.1	Choosing colours	10
5.1.2	Curves and shapes	10
5.1.3	Tile alignment	10
5.2	Seratone® in aluminium frames	10
5.3	Seratone® AQUA PLUS™ frameless panels	10
5.4	Seratone® jointers	11

<b>6</b>	<b>Installation</b>	<b>12</b>
6.1	Planning and installation	12
6.2	Splashback installation	12
6.3	Getting started	13
	Recommended sealant/adhesive/promoter/cleaner/tape	
6.4	Planning	15
6.4.1	Timber framing	15
6.4.2	Lined wall and ceilings	15
6.4.3	Concrete and masonry walls and all ceilings	16
6.4.4	Renovations	16
6.4.5	Check sheets & preconditioning	16
6.4.6	Removing the packaging and protective film	17
6.4.7	Cutting sheets	17
6.4.8	Cutting jointers	18
6.5	Fixing	19
6.6	Fixing onto plasterboard/lining	21
6.7	Fixing directly onto timber studs	22
6.8	Fixing directly onto galvanised steel studs	22
6.9	Installation using aluminium or PVC jointers	23
6.9.1	At the installation starting point	23
6.10	Installation using silicone joints for Seratone®	24
6.10.1	At the installation starting point	24
6.10.2	Penetration silicone and sealant application	25
6.10.3	Maintaining a silicone joint	25
6.10.4	Silicone usage	25
6.11	Specific wet area installation	26
6.11.1	Shower installation options	26
6.11.2	Method 1: Acrylic shower tray detail	26
6.11.3	Method 2: Wall to tiled shower floor detail	26
6.11.4	Method 3: Stainless steel shower tray detail	27
6.11.5	Bath wall installation options	28
6.11.6	Shower over bath	28
6.11.7	Maintaining a silicone joint	28
6.11.8	Silicone usage	28
6.11.9	Finishing Seratone® against vinyl flooring	30
6.12	Details for Seratone® AQUA tile pattern alignment	31
<b>7</b>	<b>Health and safety</b>	<b>35</b>
7.1	Dos and don'ts	35
<b>8</b>	<b>Technical support</b>	<b>37</b>
8.1	Technical support	37
<b>9</b>	<b>Product warranty</b>	<b>38</b>
9.1	Seratone® warranty	38

# 1 Scope and interpretation

## 1.1 Purpose of this manual

This manual has been created to provide clear instructions required to successfully design, and install Seratone® AQUA and Seratone® AQUA PLUS™. Adherence to the techniques and guidelines presented in this manual will ensure the finished article is compliant with the conditions in the product warranty.

---

## 1.2 Identification

Seratone® solutions consist of a range of pre-finished panels and jointing options.

Seratone® AQUA is a compact panel suitable for interior wet and dry applications like bathroom and shower recess paneling, kitchen splashbacks, laundry walls and on ceilings. Seratone® AQUA is a water resistant surface with a Group 2-S fire resistant classification that is safe to use in all areas directly exposed to steam or moisture.

Seratone® AQUA is constructed using layers of kraft paper, dipped in resin and dried. These layers are then sandwiched between laminated top and bottom sheets, compressed and baked. A process called polymerisation melds these components together to create a solid-core panel which is extra tough and durable.

Seratone® AQUA PLUS™ is a range of pre-finished wall and ceiling panels manufactured on a high density mineral composite board.

Seratone® AQUA PLUS™ utilises a 175 micron multi-layered paint system which is fully cured using UV light. The paint contains no volatile organic compounds (VOC's) with the majority of the range available in a choice of gloss or matte finish.

Seratone® AQUA PLUS™ panels have a smooth glass like finish, providing a tough, durable, non-porous surface that resists marks, stains, steam or moisture. Panels are easy to clean, impervious to moisture and will not support mould growth. These panels can be used in dry, wet or hygiene area applications.

Please refer to section 4.1 – Limitations on page 8.

A range of colour matched aluminium jointing options to complement all the panel decors are available. Recommended white and clear silicone sealants are also available from building supply merchants.

---

## 1.3 Compliance

### 1.3.1 Seratone® AQUA

HPL / Compact laminate is an acceptable solution in E3/AS1 3.1.2, clause (d), for a wet area wall lining panel – (d) “Water resistant sheet linings finished with decorative high pressure laminate or factory applied polyurethane”. When stored, handled, installed and maintained in accordance with the Seratone® AQUA technical information that is current at the time of installation, Seratone® AQUA will meet the durability requirements of the New Zealand Building Code (NZBC) B2/AS1 and has a serviceable life of at least 15 years in wet areas and 5 years in all other internal applications.

### 1.3.2 Seratone® AQUA PLUS™

When stored, handled, installed and maintained in accordance with Technical Information that is current at time of installation, Seratone® AQUA PLUS™ will meet the durability requirements of the New Zealand Building Code (NZBC) B2/AS1 and has a serviceable life of 15 years in wet areas and 5 years in all other internal applications.

#### Acceptable Solution E3/AS2

Internal Moisture Acceptable Solution E3/AS2 references the Internal Wet Area Membranes Code of Practice for the selection, design and installation of internal wet-area membrane systems that help protect buildings from the effects of overflow and water splash when required as part of clauses E3.3.2 – E3.3.6 of the New Zealand Building Code (NZBC).

If you are using Acceptable Solution E3/AS2 it is important to understand that exceeding the NZBC is optional not mandatory.

Laminex New Zealand® will not be liable to any persons if the conditions as to storage, handling, installation and maintenance of Seratone® as outlined within this document are not complied with. It is the obligation of the installer of the Seratone® to convey this information to the relevant owner/occupant.

---

## 1.4 Make sure your information is up to date

When specifying or installing Laminex New Zealand® product, ensure you have the current technical manual. If you are not sure you do, or you need more information, visit [laminex.co.nz](http://laminex.co.nz) or call Laminex New Zealand® on 0800 303 606.

# 2 General product description

## 2.1 Seratone® AQUA and Seratone® AQUA PLUS™ uses

- Wall and ceiling linings where health regulations require the use of water and chemical resistant lining materials for cleaning and maintenance of surfaces.
- Wall and ceiling linings in commercial, industrial and agricultural hygiene areas, and heavy wash down areas.
- Service and food processing areas in hotels, motels and fast food outlets.
- Bathroom, laundry, shower wall and ceiling linings.
- Pre-finished decorative wall or ceiling linings.
- Splashbacks.
- Retail fitouts.
- Sliding cupboard and wardrobe doors.
- Flush door facings.
- Cabinetry facings.
- Furniture.
- Feature panels.
- Display areas.
- For refurbishment work over existing linings.
- Partitioning.
- Signage.

## 2.2 Seratone® range

As outlined below, Seratone® is available in various panel options with colour matched or powder coated aluminium jointers 2700mm in length.

Table 2.1

Seratone® Range Sheet Sizes			
Sheet sizes (mm)	2400 x 900	2400 x 1200	2700 x 1200
Seratone® AQUA	–	All decors.	Polar White Gloss only.
Seratone® AQUA PLUS™	Polar Gloss & Polar Satin only.	Polar Gloss, Polar Matte, Summit Gloss, & Summit Matte only.	Polar Gloss, Polar Matte, Shell Gloss, Shell Matte, Canvas Gloss, Canvas Matte, Summit Gloss, Summit Matte, Mineral Gloss, Meteor Gloss & Meteor Matte only.

# 3 Material properties

## 3.1 Seratone® AQUA product details

Table 3.1 Seratone® AQUA Sheet details

Sheet Details			
Sheet sizes (mm)	Nominal thickness (mm)	Mean weight (kg/m <sup>2</sup> )	Sheet weight per panel (kg)
2400 x 1200	4.5	6.64	20
2700 x 1200 <sup>+</sup>	4.5	6.64	21.5

<sup>+</sup>Polar White Gloss only  
All measurements are nominal.

Table 3.2 Seratone® AQUA sheet tolerances

Sheet Tolerances	
<b>Length and width (mm)</b>	+/-2mm
<b>Squareness</b>	The difference between the measured diagonals is no greater than 1.5mm – mm/m
<b>Thickness (mm)</b>	4.36mm – 4.5mm

All measurements are nominal.

Table 3.3 Seratone® AQUA details

Product Details			
Property	Unit	Measure	Standard
<b>Application</b>			VGS (Vertical General Purpose Standard)
<b>Weight</b>	kg/m <sup>2</sup>	6.64 kgs/m <sup>2</sup>	
<b>Resistance to surface wear</b>		Initial wear not less than 50 cycles. Average wear not less than 150 cycles <sup>^</sup> .	AS/NZ 2924.1 1998
<b>Resistance to immersion in boiling water</b>		No deterioration other than slight loss of gloss. Gain in weight of not more than 5%.	AS/NZ 2924.1 1998
<b>Resistance to dry heat at 180°C</b>		No deterioration other than slight loss of gloss and/or colour.	AS/NZ 2924.1 1998
<b>Resistance to steam</b>		No deterioration other than slight change of gloss and/or colour.	AS/NZ 2924.1 1998
<b>Dimensional stability</b>		Dimensional change of not more than 0.3% with grain and 0.65% across grain.	AS/NZ 2924.1 1998

Table 3.4 Seratone® AQUA details Cont.

<b>Resistance to staining</b>	Reagents groups 1 & 2 = no visible change. Reagents groups 3 & 4 = slight change of colour and/or gloss.	AS/NZ 2924.1 1998
<b>Resistance to colour change in artificial light*</b>	Not more than slight colour change in Xenon arc light (min. 6 on Blue Wool Scale).	AS/NZ 2924.1 1998
<b>Resistance to cigarette burns</b>	No deterioration other than moderate change in gloss and moderate brown staining.	AS/NZ 2924.1 1998

^ Not applicable to Polar White Ripple Gloss. This product is for low duty wear use only, average wear point of 10 cycles.

\*Seratone® AQUA has good colour retention in normal interior applications, however prolonged exposure to sunlight may cause some change in colour. Seratone® AQUA is therefore not recommended for exposed external applications and any prolonged exposure to direct sunlight should be avoided.

### 3.2 Seratone® AQUA PLUS™ product details

Table 3.5 Seratone® AQUA PLUS™ sheet details

<b>Sheet Details</b>			
Sheet sizes (mm)	Nominal thickness (mm)	Mean weight (kg/m <sup>2</sup> )	Mean weight per panel (kg)
2400 x 900	4.5	8.35	18.03
2400 x 1200	4.5	8.35	24.04
2700 x 1200	4.5	8.35	27.05

Sheet size varies by décor. Refer to table 2.1.  
All measurements are nominal.

Table 3.6 Seratone® AQUA PLUS™ sheet tolerances

<b>Sheet Tolerances</b>	
<b>Length and width (mm)</b>	± 0.1mm
<b>Squareness</b>	The difference between the measured diagonals is no greater than 3.0mm.
<b>Thickness (mm)</b>	± 0.2mm from the nominal.



Table 3.7 Seratone® AQUA PLUS™ substrate properties

<b>Substrate Properties</b>			
<b>Property</b>	<b>Performance figures</b>	<b>Units</b>	<b>Standard</b>
Thickness	4.5	mm	ISO 4593:1993
Density	1.88	g/cm <sup>3</sup>	ISO 845:2006
Charpy unnotched impact strength	8.77	kJ/m <sup>2</sup>	ISO 179-1:2023
Shore hardness	D/15:80	D	ISO 868:2003
Tensile strength	13.5	MPa	ISO 527-2:2012
Tensile modulus	4580	MPa	ISO 527-2:2012
Vicat softening temperature	85.7	°C	ISO 306:2022
Deflection temperature under load	74	°C	ISO 75-1:2020 ISO 75-2:2013
Thickness swelling in water	0.10	%	EN 317:1993
Surface water absorption	8.7	g/m <sup>2</sup>	EN 320:2011
Formaldehyde content	No detected	mg/100g	EN 120:1992
Moisture content	2.1	%	EN 120:1992
Srew withdrawal resistance	1160	N	EN 320:2011
Srew withdrawal resistance	258	N/mm	EN 320:2011

# 4 Durability

## 4.1 Limitations

- Seratone® panels must not be subjected to submersion or continuous permanent contact with water.
- Continuous intermittent contact is acceptable for both Seratone® AQUA and Seratone® AQUA PLUS™. Do not use in saunas or steam rooms.
- Some slight fading may be experienced over the course of time when exposed to direct sunlight.
- Seratone® is only suitable for use between -20°C and up to a maximum of 50°C for medium or long term exposure. For short term exposure maximum temperature should not exceed ambient temperature plus 65°C.
- Seratone® is not intended for use as a wall bracing panel.
- Use of Seratone® as whiteboards may leave ghosting from some inks, and is therefore not recommended.
- Seratone® panels are not intended for use in exposed exterior locations.

## 4.2 Handling and storage

Seratone® Panels must be stored in dry conditions and handled in accordance with this document.

- Keep sheets flat by stacking on evenly spaced bearers (gluts) which extend across the full sheet width (refer to Figure 1).
- When stacking high, line gluts vertically one above the other.
- Care of the sheet face is essential to protect the decorative surface.
- To avoid damage to the surface, lift rather than drag the sheets off the stack.
- Leave protective film on panels intact, until ready for use (see page 14, 6.4.6).

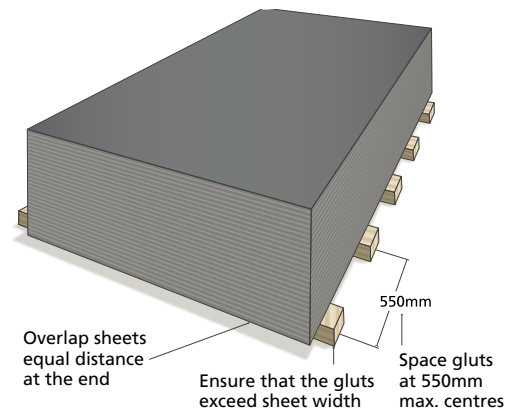

Figure 1. Storing Seratone® panels

## 4.3 Cleaning

Recommended cleaning products: Jif Powerspray®, Sunlight liquid®, Ajax spray 'n' wipe® – multi-purpose, kitchen antibacterial, bathroom antibacterial, Handy Andy®, Shower Witch®, domestic strength diluted bleach.

- Adhere to cleaner manufacturer's instructions.
- Always use a soft cloth.
- Do not use scouring pads or abrasive cloths (e.g. steel wool) or cream cleaners as these may damage the surface.
- The removal of dust from the surface can be easily achieved by the use of an electrostatic dusting cloth (e.g. Johnson's Pledge® Grab-it).

#### 4.4 Durability conditions

Seratone® will meet the durability requirements of the New Zealand Building Code (NZBC) B2/AS1 and has a serviceable life of 15 years in wet areas.

Seratone® will meet the durability requirements of the New Zealand Building Code (NZBC) B2/AS1 and has a serviceable life of 5 years in all other internal applications.

Laminex New Zealand® will not be liable to any person if the conditions as to storage, handling, installation and maintenance of Seratone® panels as outlined within this document are not complied with. It is the obligation of the installer of the Seratone® panels to convey this information to the relevant owner/occupant.

#### 4.5 Moisture content

The dimensions of Seratone® panels can be affected by changes in relative humidity. Therefore, conditioning in the environment in which the sheet will be installed is required. This is best achieved by flat stacking sheets with fillets between and leaving for a minimum of 48 hours prior to installation.

In some cases, it may be prudent to extend the conditioning time. e.g. where damp site conditions prevail or where large continuous runs of lining will be installed (over 6 lineal metres).

#### 4.6 Permeability

Seratone® AQUA and Seratone® AQUA PLUS™ panels are resistant to moisture penetration and are totally impermeable.

#### 4.7 Effects of heat

Seratone® panels are combustible and therefore must be separated from chimneys, fireplaces, heaters, flues and fuel burning appliances. Part 7 of NZBC Acceptable Solutions C/AS1 - C/AS2 and NZBC Verification Method C/VM1 provide methods for separation and protection of combustible material from heat sources.

#### 4.8 Fire properties

The Group Number Classifications are generated from tests carried out and data produced in accordance with the test procedure described in ISO 5660 2002 – Reaction to Fire test – Part 1: Heat Release and Part 2: Smoke Production Rate, and ISO 9705 Reaction to Fire test: Part 1. for the purposes of determination of the Group Classification in accordance with the New Zealand Building Code Verification Method C/VM2. Appendix A (refer table 4.1).

*Table 4.1 Fire Properties*

Product	Group Classification	Test Method
Seratone® AQUA	2-S	ISO 9705
Seratone® AQUA PLUS™	3	ISO 5660

# 5 Design considerations

## 5.1 Design considerations

### 5.1.1 Choosing colours

Dark, high gloss colours are more likely to highlight finger marking and wear and tear. Careful consideration should be taken when selecting these colours for harshly lit or high use areas.

Care should be taken when choosing gloss colour finishes to ensure they are suitable for a given lighting situation. Lighter colours are more tolerant of harsh lighting environments.

### 5.1.2 Curves and shapes

Seratone® AQUA PLUS™ can be curved to a minimum radius of 1500mm. It can be CNC or laser cut, making it ideal for feature panels, corporate identification, or signage.

Seratone® AQUA is a compact laminate and is non-postformable, curving is not recommended.

### 5.1.3 Tile alignment

To ensure perfect tile pattern alignment for Seratone® AQUA Herringbone, Subway and Square Tiles, cutting of sheets will be required when continuous runs of sheets are installed. It is recommended this is allowed for when planning the installation of the sheets.

---

## 5.2 Seratone® in aluminium frames

Both Seratone® AQUA and Seratone® AQUA PLUS™ can be easily cut and shaped for use in sliding and conventional opening aluminium door systems. They can also be used in aluminium frames for office partitioning and furniture.

---

## 5.3 Seratone® AQUA PLUS™ frameless panels

You can create the thickness you require for standard concealed hinges or where a thicker or double-sided panel is required. Seratone® AQUA PLUS™ can be laminated to panel products such as MDF, using the recommended adhesives. Edges can be finished using timber clashing or the edges can be painted.

## 5.4 Seratone® jointers

Seratone® fixing system profile jointers have been developed by Laminex New Zealand® to stylishly integrate joins and minimise areas where mould and grime could gather in both wet and dry area applications. Jointers come in 2700mm lengths.

Seratone® aluminium jointers and PVC mouldings can be cut with a fine-toothed tungsten tipped drop saw, or a fine-toothed hack saw. Ensure all cutting blades are sharp prior to use.

*Figure 2. Seratone® Jointers available in 4.5mm thickness*

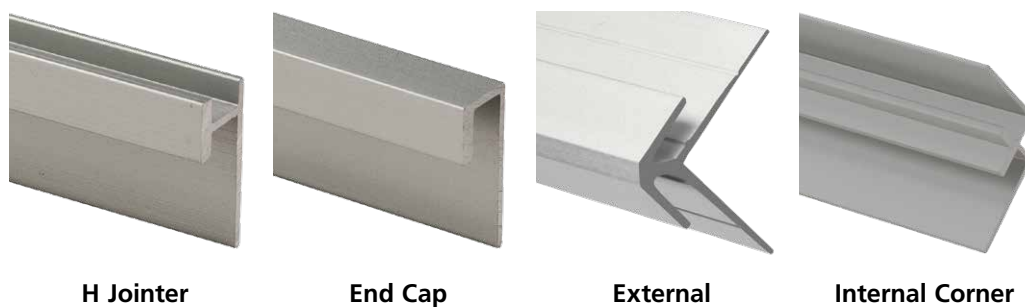

**H Jointer**

**End Cap**

**External**

**Internal Corner**

# 6 Installation

## 6.1 Planning and installation

Seratone® sheets are relatively simple to install using construction adhesive and if desired double-sided tape. Panels can be fixed directly to a timber frame wall or it can be laid over a range of substrates, such as plasterboard, Strandboard®, Medium Density Fibreboard (MDF) and fibre cement. When planning an installation, it is important to select the most appropriate jointing and fixing method to achieve the desired result.

## 6.2 Splashback installation

Seratone® can be used as a splashback (which can be applied directly onto framework, or existing linings). Prior to installation of sheets into kitchens, refer to design considerations section. Due to heat and cleaning requirements where Seratone® is being used as a splashback, it is recommended that 'full sheets' are used wherever possible (avoid joins).

The following distances must be adhered to:

**ELECTRIC COOKTOP:** Seratone® panels can be used as a splashback material behind an electric cooktop provided it is kept at a distance of at least 100mm from the periphery of the nearest heating element.

**GAS COOKTOP:** Seratone® panels can be used as a splashback material behind a gas cooktop provided it is kept at a distance of at least 200mm from the periphery of the nearest gas trivet.

Figure 3. Electric Cooktop

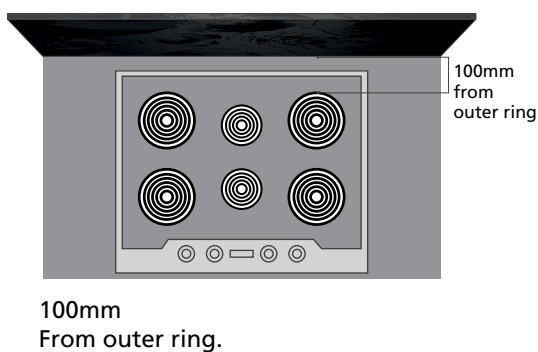
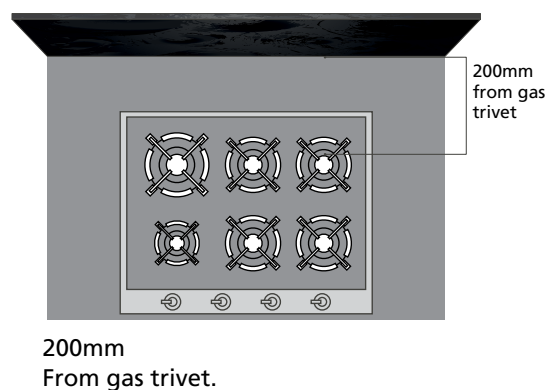

Figure 4. Gas Cooktop



### 6.3 Getting started

Tools and accessories (products not supplied by Laminex New Zealand®)

Figure 5. Source appropriate tools and accessories

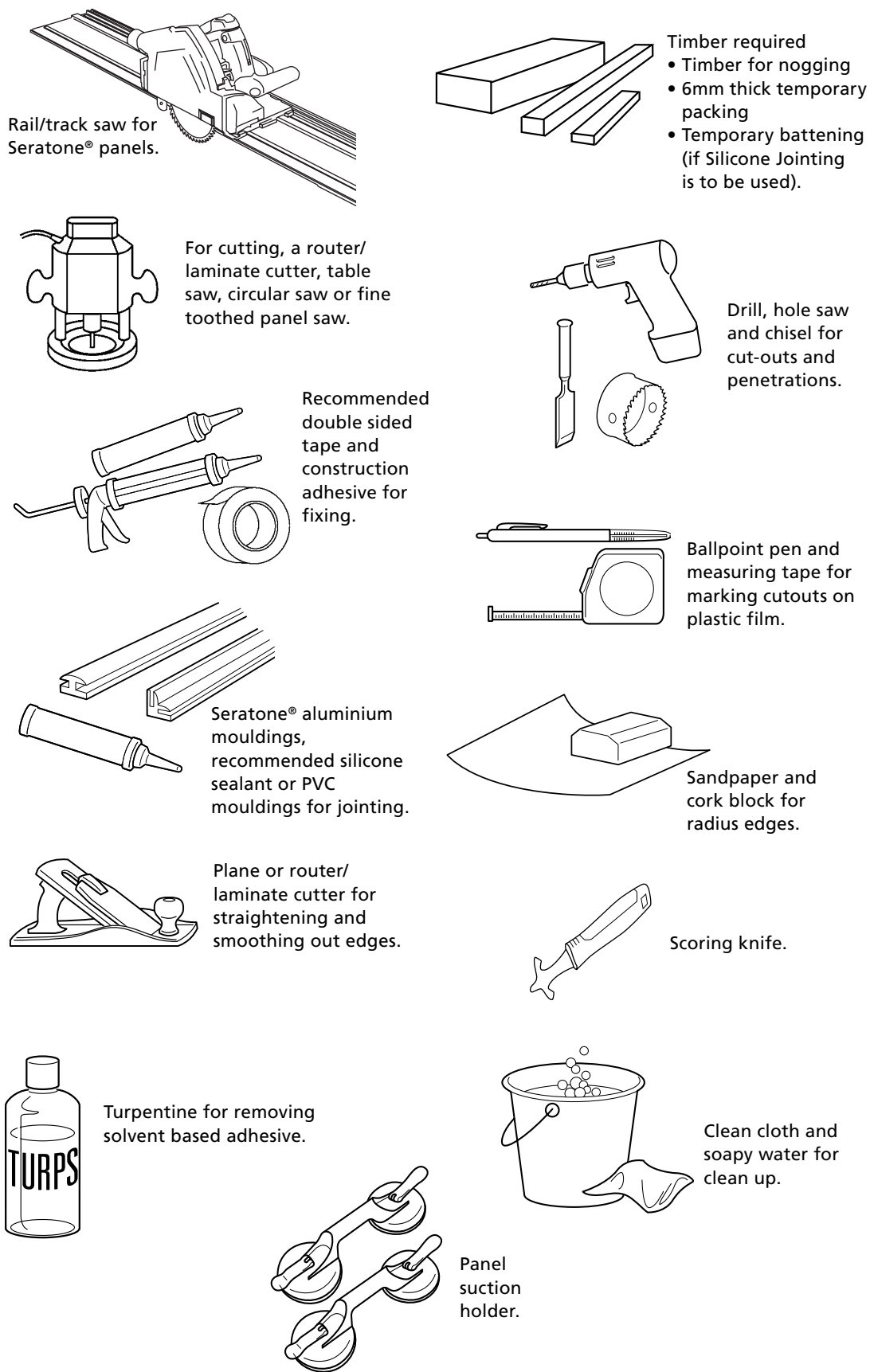

Table 6.1 Recommended sealant/adhesive/promoter/cleaner/tape

Application / Use	Product Name / Description	AQUA	AQUA PLUS™ Gloss	AQUA PLUS™ Matte
Sealant	Sikaflex® 123 MS Bond*	✓		
	Sikaflex® NG	✓	✓	
	Sika Sikasil® – Wet Areas Silicone	✓	✓	✓
	Fuller Sanitary 770	✓	✓	✓
	Gorilla MS Sealant*	✓	✓	✓
	Soudal Soudaseal 240FC MS*	✓	✓	✓
	Gorilla Kitchen & Bathroom Sealant	✓	✓	✓
Adhesive	Sika® Nail Bond Fast		✓	✓
	Sikaflex® 123 MS Bond*	✓	✓	✓
	HB Fuller Maxbond		✓	✓
	Gorilla MS Sealant*	✓	✓	✓
	Soudal Soudaseal 240FC MS*	✓	✓	✓
	Gorilla Shower Grab		✓	✓
	Fix All Hi Tack*	✓	✓	✓
	Gorilla Grab Adhesive		✓	✓
Adhesion Promoter / Solvent Cleaner	Soudal Primer 150 (for best results use with Gorilla MS Sealant*, Fix All Hi Tack* & Soudal Soudaseal 240FC MS*)		✓	✓
	Gorilla Surface Activator	✓		
	Sika® 205 Solvent Aktivator (for use with Sikaflex® 123 MS BOND)	✓	✓	✓
Double Sided Foam Tape	Gator Double Sided Foam Tape (12mm x 2mm x 30m)	✓	✓	✓
	Danco 6620	✓	✓	✓
	3M™ VHB™ Heavy Duty Mounting Tape	✓	✓	✓

**IMPORTANT | ADHESIVES**

The recommended adhesives listed will adhere to timber and steel framing, clean plasterboard, Strandboard® and Medium Density Fibreboard (MDF) surfaces. For any alternative linings or surfaces including applied finishes, an adhesion test is recommended before full application.

**\*Non-porous substrates**



Laminex New Zealand® recommends the use of MS polymer adhesives such as Sikaflex® 123 MS Bond, Gorilla MS Sealant, Soudal Soudaseal 240FC MS or Fix All Hi Tack for bonding to non-porous surfaces.

Always refer to the adhesive manufacture's technical data sheets for further information on curing times and possible surface preparation requirements.

## 6.4 Planning

When planning your design and installation, remember not all wall/ceiling/floor intersections are square. It is therefore advisable to begin in the centre of the wall or ceiling with a full Seratone® panel.

- Plan for part sheets to be placed at the corners of the room.
- Ensure sheet joints (and jointers where appropriate) coincide with the centre of studs or supports when installing directly to timber framing.
- Complete plan for joint sequence layout.

### Note

1. Sheets are usually installed vertically on walls, they can also be fixed with long edge laid horizontally for contrast or to create a feature in a dry area. If sheets are to be laid horizontally, ensure continuous support is provided behind all joints. Ensure all sheets are installed in the same direction.
2. Laminex New Zealand® do not recommend installing sheets in a horizontal orientation in shower enclosures or wet area rooms. If the sheet is to be installed horizontally (along the wall) in wet areas where water runs over the sheet face, silicone must be used to form the join between the two sheets (do not use an aluminium jointer).

### 6.4.1 Timber framing

- Ensure the timber support (nog/dwang/batten/stud) faces are straight, in alignment and flush.
- Studs and nogs need to be at 600mm maximum centres for 1200mm wide sheets and 450mm for 900 wide sheets. For ceilings, suitable sized battens should be spaced at 400mm maximum centres.
- Ensure all support surfaces to be bonded are clean and dry (maximum moisture content is 18%).

### 6.4.2 Lined wall and ceilings

- Walls and ceilings lined with plasterboard, or similar are suitable for direct fixing providing the surface is flat, sound and properly fixed.

### 6.4.3 Concrete and masonry walls and ceilings

- Do not fix directly to concrete and masonry walls.
- Install nominal 35 x 45mm timber or steel battens. Fix battens with masonry with nails or screws.
- Strapping and battens must have a damp-proof course between timber and concrete.
- New and old concrete / masonry walls shall be dry before installing Seratone® panels. The only true method is to measure the relative humidity of the concrete surface, using a hygrometer. Ensure the reading is below 70% before installing the Seratone® panel.
- Ensure that all exterior wall faces are adequately sealed. Application of a waterproof membrane may be required to prevent ongoing moisture issues.
- For ceilings, suitable sized timber battens or metal furring channels should be spaced at 400mm maximum centres.

Figure 5. Masonry wall

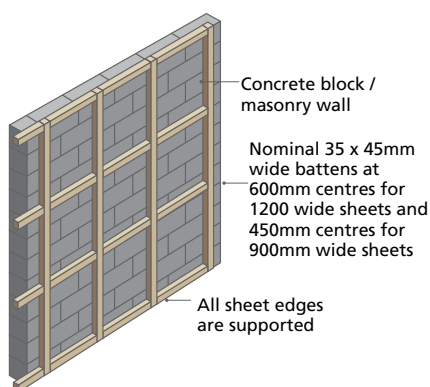
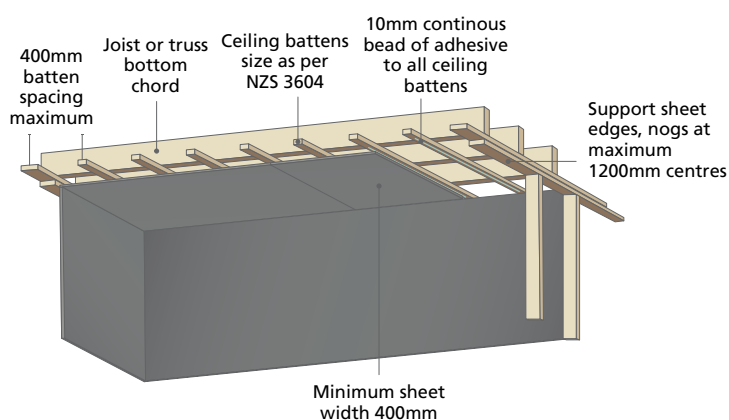

Figure 6. Fixing to ceilings



### 6.4.4 Renovations

- When using Seratone® panels to reline over existing walls or ceilings, previously painted surfaces should be cleaned, then scuffed with coarse abrasive paper to form a key for adhesion.
- Old shower linings must be removed before installation of new sheets. Existing framing and plumbing should be inspected to ensure no degradation has occurred.
- Check the adhesive does not soften old paint work.

### 6.4.5 Check sheets & preconditioning

- Always check for colour match when sheets are on the same wall plane or where colour/shade matching is critical. For areas where colour matched sheets are desired order as "batch matched" to minimise colour variation.
- Precondition panels. Fillet stack pairs of panels and leave for at least 48 hours in the room where they will be installed. In some cases, it may be prudent to extend the conditioning time. e.g. where damp site conditions prevail or where large continuous runs of lining will be installed (over 6 lineal metres).

#### 6.4.6 Removing the packaging and protective film

- A sheet of protective film protects the face of each Seratone® sheet. This film is designed to keep the sheet clean and to protect against scratches. The film should be removed in two stages:
  1. Initially, 50mm should be removed from all edges to allow for jointing/sealing.
  2. Only when the sheet is completely installed should the remainder of the film be removed.

#### 6.4.7 Cutting sheets

##### Seratone® AQUA

- When cutting Seratone® AQUA, a track saw (Festool or similar) or a high speed laminate cutter (30,000 + rpm) with a 6mm blade should be used.

##### Seratone® AQUA PLUS™

- To cut Seratone® AQUA PLUS™, you can use a laminate cutter or router.
- Horizontally measure the top and bottom of the wall to determine the sheet width required, as not all walls are square.
- Use a ballpoint pen to gently mark these measurements onto the protective film.
- Always support the panel, using a table or sheet material. The use of a felt blanket, or the like, reduces scratching or indentation.
- Panels can be cut to size.
- Always ensure that all cutting blades are sharpened prior to use.

##### Circular saw

- Normally the blade rotation of a circular saw is up. If this is the case, cut sheets with decorative surface down. If blade rotation is down, cut sheet with decorative surface face up (therefore the blade is cutting into the decorative surface, avoiding 'chip out').
- Clamp a straight edge to the sheet as a guide for the tool. Place a piece of timber material under the line you will be cutting. This supporting material is important as it helps reduce the chipping of the decorative surface.
- Reduce the depth of cut to allow the blade to cut approximately 7mm through the sheet.
- Cut the sheet using the circular saw, cutting slowly with a sharp, high quality tooth blade.
- Allow the sheet to pass through the saw with even pressure – do not force the sheet.

##### Scoring knife

- Horizontally measure the top and bottom of the wall to determine the sheet width required, as not all walls are square.
- Use a ballpoint pen to gently mark these measurements onto the protective film.
- Clamp a straight edge to the sheet as a guide, apply even pressure and score the face of the panel.
- Remove the straight edge and position the sheet with the score cut on the edge of the supporting bench / worktable and "snap" the sheet along the cut.

**Handsaw (not recommended for Seratone® AQUA)**

- A fine-tooth hand saw may be used to cut Seratone® AQUA PLUS™, with the decorative surface face up.
- Mark the sheet for the cut.
- Hold the blade of the hand saw at a very low angle, so that it is almost flat to the face of the board. Cut slowly and carefully with even strokes.
- Once cut with a hand saw, clean the cut edges with a plane or very fine sandpaper (e.g., 320 grit).

**Finishing Seratone® panel edges after cutting**

- Use a laminate cutter, router or electric plane to finish the edge.
- When using an electric plane, ensure it is held square to the edge of the sheet. The sheet should be well supported and secured.
- Lightly chamfer any cut made to Seratone® AQUA with a block and 320 grit paper, to remove the arras and any ragged edges.

**Cutting Seratone® panel for penetrations**

- Measure and mark cut outs for light boxes, pipe fittings etc., ensuring sufficient clearance is allowed.
- All internal corners shall have a minimum 5mm radius (power outlets etc.).
- Ensure that cover plate/tap flanges cover the penetrations.
- In wet areas, run a bead of silicone around fittings/cut outs on the face of the board before fitting face plates and tap flanges etc. (see Figure 6).
- For best results with Seratone® AQUA use drill hole and use router with laminate cutter bit for holes and penetrations.
- Always use an electrician when working around electrical outlets.
- Any internal corner or aperture must be cut with a minimum internal radius of 5mm. All edges must be smooth and free of damage, cracks, dents or notches.
- Cracks or any failure attributable to non-compliant openings or cut-outs will not be recognised under warranty.

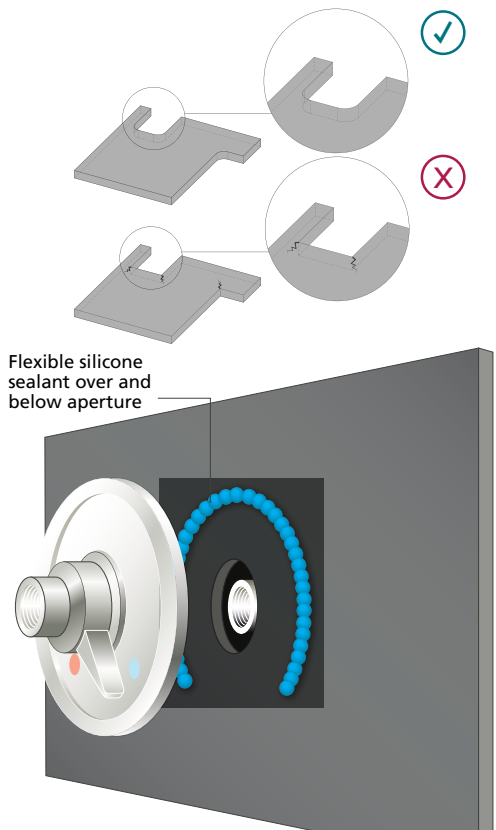

Figure 7. Penetrating panels for wet area installations

**6.4.8 Cutting jointers**

- Seratone® aluminium jointers and PVC mouldings (available from various building product suppliers) can be cut with a fine-toothed tungsten tipped drop saw, or a fine toothed hack saw. Ensure all cutting blades are sharp prior to use.

## 6.5 Fixing

Refer to Table 6.2 for jointing and fixing methods and Table 6.4 for sheet fixing instructions.

### Jointing and fixing methods

Table 6.2 Jointing and fixing methods – Preferred jointing method

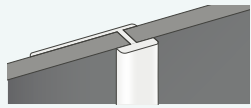
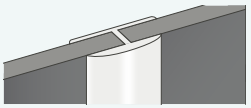
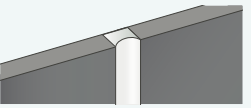
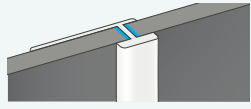
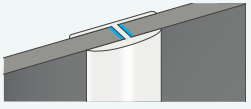
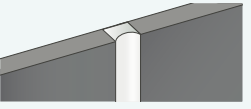
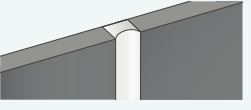
Application Type	Aluminium Mouldings	PVC Mouldings	Silicone Sealant
Dry area			
Wet area			
Hygiene area			

<b>Substrate</b> (The surface you are fixing Seratone® to)	Framing or plasterboard/lining
<b>Recommended fixing method</b>	Construction adhesive or tape and construction adhesive

\* Blue lines are silicone sealant.  
 \*\* An appropriate sanitary sealant for hygiene areas, such as Fuller Sanitary 770 or Gorilla Kitchen & Bathroom sealant.

Table 6.3 Installation using Aluminium Jointers (wet or dry areas)

Profile	Installation Details
<p><b>H Jointer</b></p> 	<p>Joining two sheets:</p> <p><b>Method 1:</b> Secure panel against the existing surface, then simply slide the H Jointer onto the end of the panel. Push next panel into jointer.</p> <p><b>Method 2:</b> Fix jointer by way of screws, construction adhesive or double sided tape – then slide panel into it. Screws should be counter sunk at 300mm centres.</p>
<p><b>End Cap</b></p> 	<p>First secure the jointer, then position the panel in place. Jointer can be attached using screws, construction adhesive or double sided tape. When screw fixing, the screws should be countersunk and spaced 300mm apart.</p>
<p><b>External Corner</b></p> 	<p>First secure the jointer, then position the panel in place. Jointer can be attached using screws, construction adhesive or double sided tape. When screw fixing, the screws should be countersunk and spaced 300mm apart.</p>
<p><b>Internal Corner</b></p> 	<p>Engage jointer onto edge of first panel and attach second panel to framing. Attach second sheet, locating the edge into jointer. Jointer can be attached using screws, construction adhesive or double sided tape if necessary.</p> <p>Screws should be spaced 300mm apart.</p>

Table 6.4 Fixing instructions

Fixing Method	Construction Adhesive & Tape: Wet And Dry Areas	
Layout of Tape or Adhesive (on framework and back of Seratone® panels)	Apply adhesive at 300mm centres and double sided tape at 400mm centres	Apply adhesive to horizontal framing and double sided tape to vertical framing
		
	Installation of panel with adhesive and tape method allows panels to be positioned without bracing	Installation of panel with adhesive and tape method allows panels to be positioned without bracing

Double sided tape is used in conjunction with adhesives to provide temporary support during adhesive cure. This removes necessity of bracing the panels. When installing Seratone® as a ceiling lining, it's recommended to provide some bracing.

Installation without double sided tape to both plasterboard, other substrates types, and direct to timber and metal framing requires the positioning of timber supports to hold panels against wall while adhesive cures.

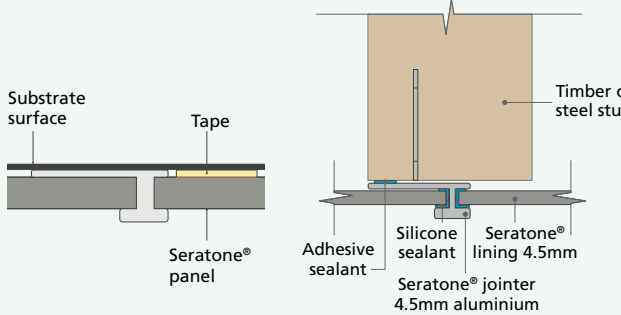
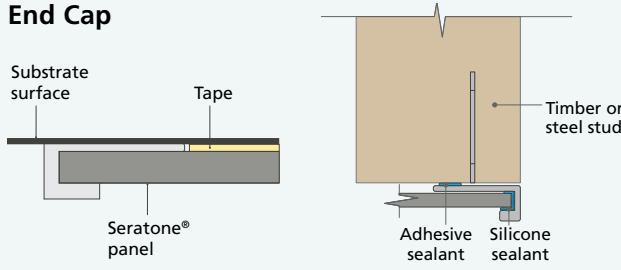
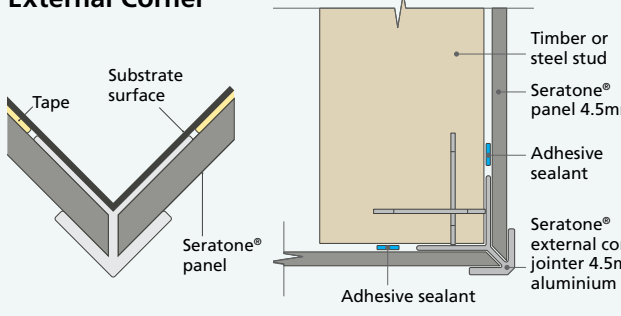
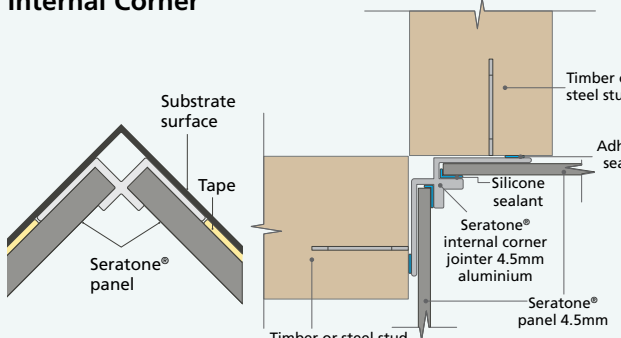
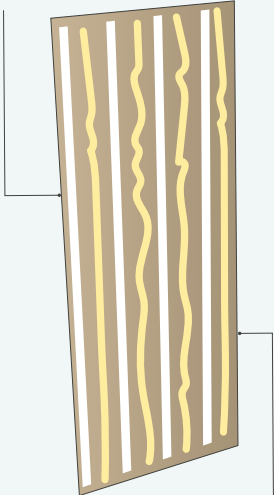
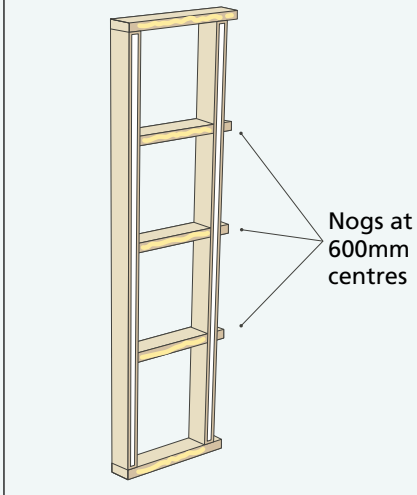
Seratone® panels may require timber supports even with the use of double-sided tape.

## 6.6 Fixing onto plasterboard/lining

- Ensure all bond surfaces are clean, dry and free from dirt, dust, oils or any other surface contaminants.
- Ensure to wipe the back of Seratone® AQUA sheet down with alcohol based cleaner (Sika® 205 Aktivator or Gorilla 696 Surface activator).
- Wipe the back of Seratone® AQUA PLUS™ sheet down with Soudal Primer 150 or Sika® 205 Aktivator.
- Apply continuous full panel length of double-sided tape to the back of the panel at 400mm centres.
- Apply continuous full panel length beads of adhesive no less than 10mm in diameter to the back of the panel at 300mm centres between the strips of adhesive tape.
- Remove tape backing, place the panel into desired position and apply pressure to ensure full contact over entire surface area of the panel.

## 6.7 Fixing directly onto timber studs

- Nogs shall be at 600mm centres (three rows of nogs when direct fixing to framing).
- Ensure all bond surfaces are clean and dry and free from dirt, dust, oils or any other surface contaminates.
- Ensure to wipe the back of Seratone® AQUA sheet down with alcohol based cleaner (Sika® 205 Aktivator or Gorilla 696 Surface activator).
- Wipe the back of Seratone® AQUA PLUS™ sheet down with Soudal Primer 150 or Sika® 205 Aktivator.
- Apply continuous full panel length beads of double-sided tape to the right or left of centre of each vertical stud where two panels will be joined (edge stud). Allow sufficient room between the two strips of double-sided tape for the jointer to be located (no adhesive will be applied to these studs).
- Apply continuous panel length strips of doubled-sided tape to the right of centre of each vertical stud that is not supporting the edge of a sheet (centre stud).
- Apply continuous panel length beads of adhesive no less than 10mm in width next to the strips of double-sided tape on each centre stud. Each stud supporting the sheet edge should now have a strip of double-sided tape and each stud supporting the centre of the sheet should have both a strip of tape and adhesive.
- Apply a continuous bead of adhesive over the length of the horizontal timber frame components (nogs).
- Remove tape backing. Place the panel into desired position and apply pressure to ensure full contact between the framing and the panel.

## 6.8 Fixing directly onto galvanised steel studs

- Ensure all bond surfaces are clean, dry and free from dirt, dust, oils or any other surface contaminants.
- Scuff surface of galvanised framing with Scotch-Brite™ (or the like).
- Apply a degreaser (e.g. Sika® 205 Aktivator or similar) with a clean dry rag and wipe off with a separate clean dry rag.
- Allow the degreaser to fully flash off the bond surface before applying adhesive.
- Ensure to wipe the back of Seratone® AQUA sheet down with alcohol based cleaner (Sika® 205 Aktivator or Gorilla 696 Surface activator).
- Wipe the back of Seratone® AQUA PLUS™ sheet down with Soudal Primer 150 or Sika® 205 Aktivator.
- Apply continuous full panel length beads of adhesive no less than 10mm in width to each stud.
- Apply a continuous bead of adhesive over the length of the horizontal steel frame components.
- Place the panel into desired position and apply pressure to ensure full contact between the steel framing and the panel.
- Position timber supports to ensure pressure is provided while the adhesive cures.

Apply adhesive to horizontal framing and double sided tape to vertical framing

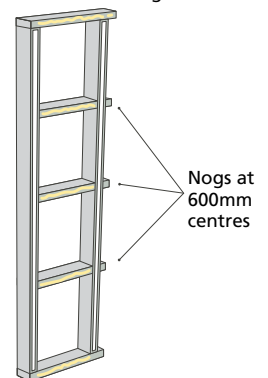

Installation of panel with adhesive and tape method allows panels to be positioned without bracing

Figure 8.



## 6.9 Installation using aluminium or PVC jointers

The aluminium and PVC jointing systems are designed for use in both wet and dry areas (refer to Table 6.3). PVC jointers are available from various building product suppliers.

The system is suitable for installation on fully lined walls/ceilings (plasterboard) or direct to timber studs.

### 6.9.1 At the installation starting point

- For cutting Seratone® Jointers, refer to Page 17.
- Mark out areas for penetrations on protective film and cut.
- Take the first Seratone® panel and peel the protective film approximately 50mm from the edge – refer to Figure 9.
- For PVC jointers, nail jointer in place using galvanised flat head nails (max 30 x 2.0mm), at 300mm centres.
- For aluminium jointers screw fix (max 6g x 25 - 30mm), glue or tape in place (countersink screws at 300mm centres).
- For all wet areas, apply a continuous bead of silicone into the jointer recess before inserting the panel.
- If you have difficulties inserting panels into the jointers, lightly sand the back of the panel.
- Apply construction adhesive and/or double-sided tape to the framing or substrate (refer to Table 6.1) as per manufacturers' recommendations and fixing instructions.

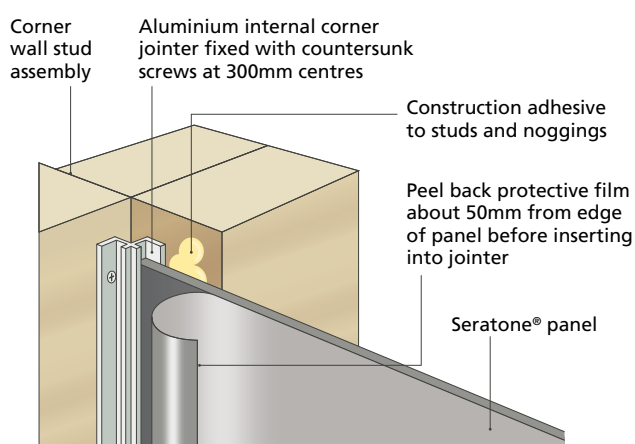

Figure 9. "Starting Point" using Internal Corner Jointers

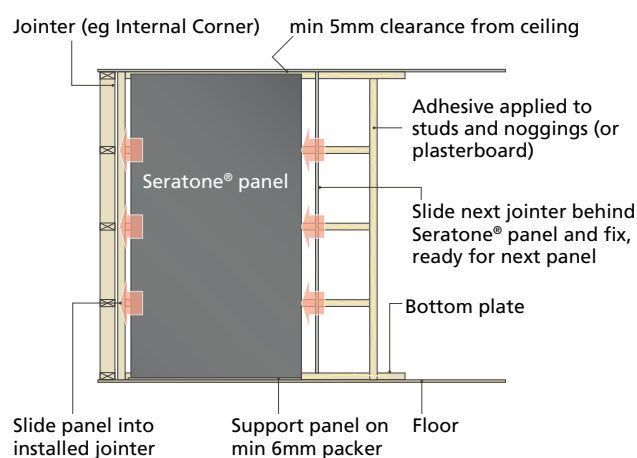

Figure 10. Installing first panel

- Insert panel into fixed jointer.
- Press the panel firmly onto the centre stud/substrate, add jointer to trailing edge, then screw or glue fix trailing jointer into place (refer to Figure 10).
- Continue installation by inserting each new panel into the jointer of the previous panel. Screw, glue or tape jointers to studs/substrates as installation progresses.
- Check for adhesive and silicone spillage, and clean off if necessary.

## 6.10 Installation using silicone joints for Seratone®

The silicone jointing system is designed for use in all areas.

The system is suitable for installation on fully lined walls, ceilings (e.g. plasterboard) or direct to timber framing.

For installation using silicone sealant, follow the following guidelines.

### Note

It is recommended that a gap based on a 1:1 ratio is created when silicone is the jointing method.

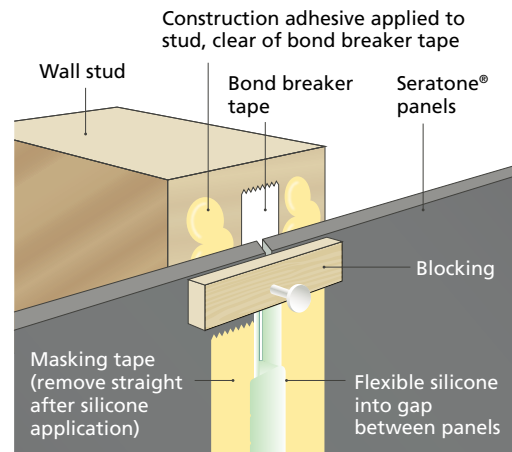

Figure 11. Installing Seratone® with silicone jointing

### Seratone® AQUA silicone joints

Seratone® AQUA is a compact panel constructed with layers of resin impregnated kraft paper, these layers are brown or black.

### Seratone® AQUA PLUS™ silicone joints

Seratone® AQUA PLUS™ is a mineral composite panel with a light grey core.

A thin black or light grey line may be visible with silicone joints if the sealant shrinks back. Painting the sheet edges with a suitable paint prior to application of the sealant will help conceal the panel edges.

#### 6.10.1 At the installation starting point

- Determine where the joints will be and fix polyethylene tape to the framing/ substrate to act as the bond breaker tape.
- Apply construction adhesive and/or double-sided tape to the framing or substrate (refer to Table 6.1) as per manufacturer's recommendations and fixing instructions. Avoid applying adhesive to the bond breaker tape.
- If fixing using construction adhesive, follow the manufacturer's recommendations.
- Fix stop nails against the trailing edge of the panel to provide the required gap between sheets.
- If fixing using construction adhesive only, temporarily brace the panel edges against the stud while the adhesive cures using blocks fixed to framing with small diameter nails. If fixing using a combination of adhesive and tape, this step is not necessary as the tape will hold the panel in place while the adhesive cures.
- Continue the process until panel installation is complete.
- Carefully remove stop nails as installation progresses.
- Clean out any adhesive showing between the panels.
- Once adhesive cures, remove blocking.
- Peel approximately 50mm of the protective film from panel edges (leave balance on the panel until installation completed).
- Carefully apply 20mm low tack masking tape to either side of the joint.
- Cut nozzle of the silicone tube to create an aperture slightly larger than the gap.

- Apply a consistent bead of silicone in gap so that it is flush with panel surface.
- Once the gap is filled, remove excess silicone with a clean, suitable tool, or a clean gloved finger – do not use unprotected finger.
- For internal corner joints refer to Figures 12 & 13.
- Clean any excess silicone off panel front by using a clean cloth and a cleaning agent specified by silicone manufacturer (before commencing, check the suitability of the cleaning agent on the Seratone® panel surface).

### 6.10.2 Penetration silicone and sealant application

- Clean any excess silicone off sheet front by using a clean cloth and a cleaning agent specified by silicone manufacturer (before commencing, check the suitability of the cleaning agent on the Seratone® sheet surface).
- Immediately after silicone is applied, carefully remove masking tape in one continuous movement (if the silicone is allowed to cure first, removing the masking tape will result in a 'ragged' edge).
- After tape is removed, do not touch the silicone joint until it is completely cured.
- Refer to the manufacturer's instructions for the appropriate silicone sealant drying time.
- Once silicone has cured, remove remaining protective film and clean sheet surfaces.

#### Option 1: Overlapped panels

Figure 12. Internal corner joint

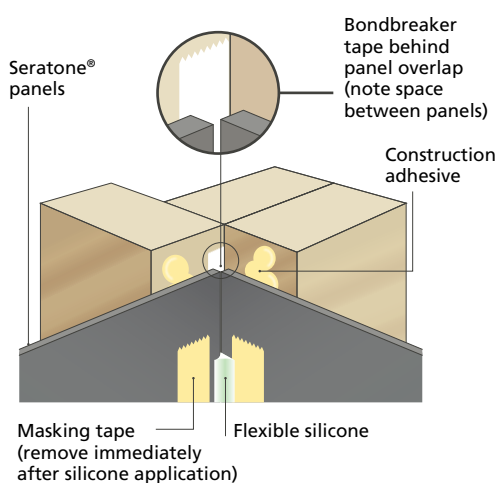

#### Option 2: Standoff panel

Figure 13. Internal corner joint

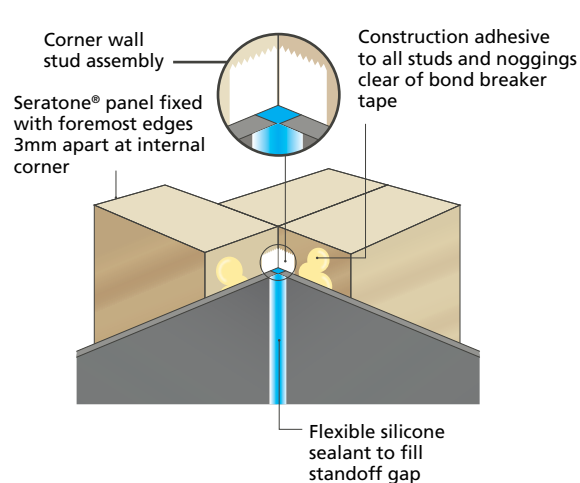

### 6.10.3 Maintaining a silicone joint

- Never wipe sealant with an ungloved finger.
- The tool used to finish the sealant surface must be free of saliva.
- Mould can grow in wet or steamy areas if attention is not paid to adequate ventilation.

### 6.10.4 Silicone usage

The amount of silicone required depends on the application, gap width and type.

As a "rule of thumb", 5 x 2.4m long joints can be achieved from one 300ml tube of silicone sealant (approximately 12m/tube).

## 6.11 Specific wet area installation

### 6.11.1 Shower installation options

There are numerous methods used to install a shower. Figures 14, 14a, 15, 15a, 15b & 15c are the most common methods, however the principles described here must be adjusted to suit the shower tray or tile manufacturer's specific instructions. No matter which methodology you use, it is essential that:

- Any silicone sealant masking should be promptly removed.
- On completion of any installation, remove the protective film and clean the surfaces.

### 6.11.2 Method 1: Acrylic shower tray detail

Figure 14.

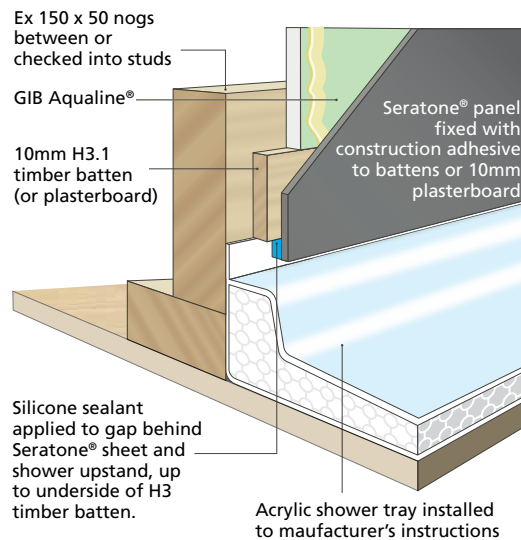
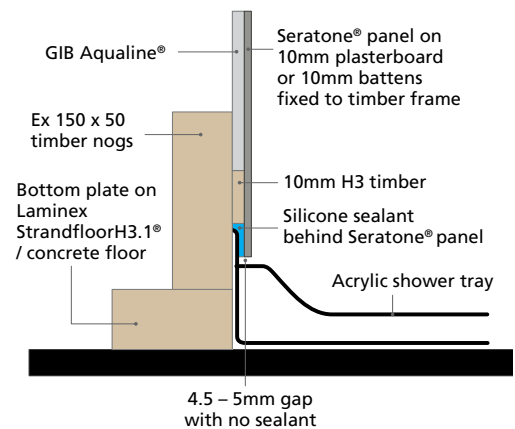

Figure 14a.



### 6.11.3 Method 2: Wall to tiled shower floor detail

Figure 15. Tile upstand

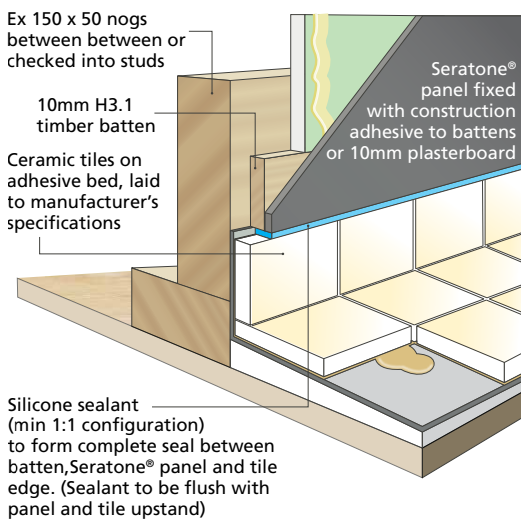
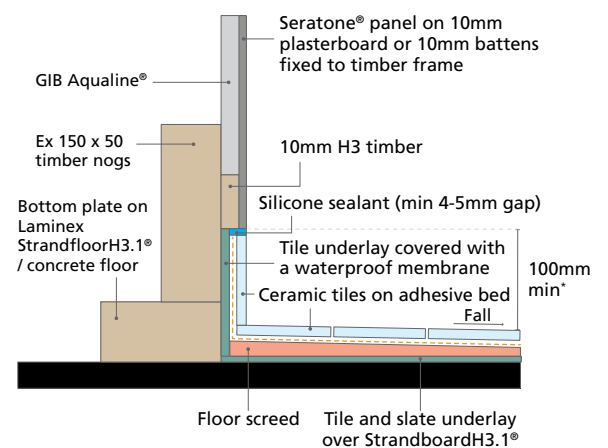

Figure 15a.



**Note:** For concrete floors underlay may be omitted from the floor surface but a full membrane is still required to the upstand.

\* Waterproof membrane is one that complies with AS/NZS 4858, or which carries a current BRANZ Appraisal.

Figure 15b. Panel to floor

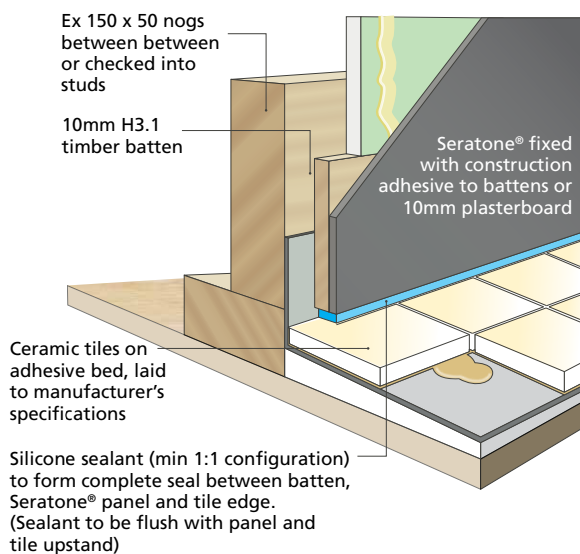
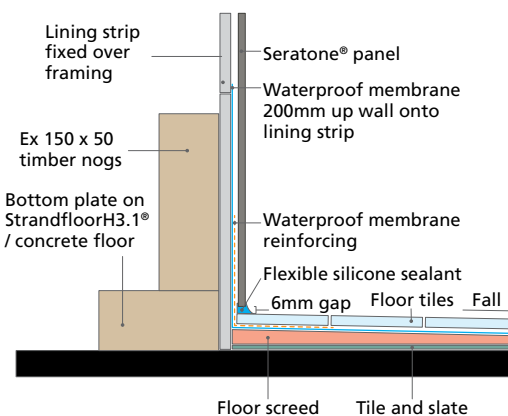

Figure 15c.



### 6.11.4 Method 3: Stainless steel shower tray detail

- Gap between face of stainless and back of Seratone® sheet should be no less than 8mm.
- Seratone® to hang below the 10mm timber batten a minimum of 10mm and no more than 35mm.
- Although not mandatory for Seratone® AQUA and Seratone® AQUA PLUS™, for an aesthetic appearance, an end cap (Standard Aluminium or PVC) can be fixed to the bottom edge of the sheet. Prior to positioning the edge of the sheet into the end cap, silicone shall be applied into the jointer channel so the channel is at least 1/3 full. When the sheet is located into the channel it is likely that silicone will be forced out of the channel up the front and back of the sheet. This action should eliminate water tracking down into the channel in the future.

### Stainless steel shower tray - drip edge detail

Figure 16.

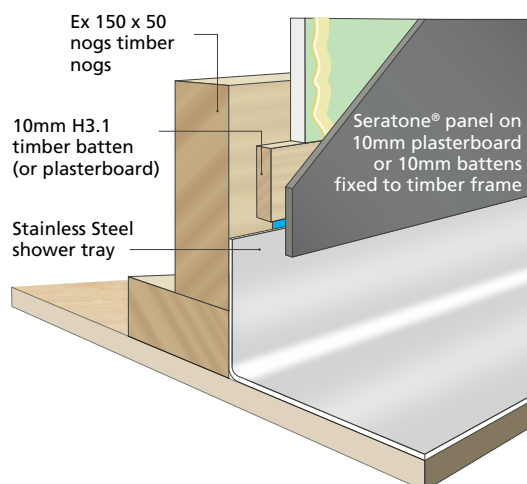
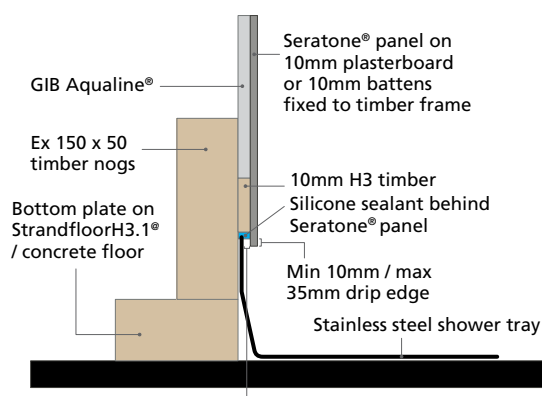

Figure 16a.



## Stainless steel shower tray - direct fix to framing / batten

Figure 16b.

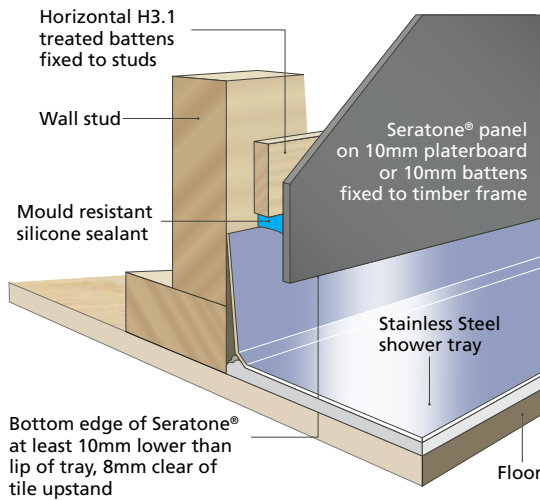
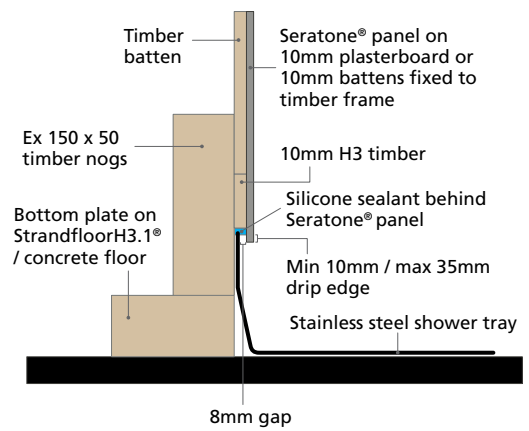

Figure 16c.



### Note

When using direct fix Method 3 – please ensure the following:

- a) The bottom edge of the Seratone® sheet hangs below the timber batten a minimum of 10mm and a maximum of 35mm.
- b) There is a gap of at least 8mm between the stainless steel upstand and the back of the Seratone® panel.
- c) A bead of sealant is applied immediately below the timber batten before the Seratone® sheet is installed.

### 6.11.5 Bath wall installation options

There are numerous baths available from many different manufacturers. The principles shown in Figures 17, 17a, & 18 should be adjusted to suit the manufacturer's specific instructions.

- Refer to bath manufacturer's installation guidelines and typical details.

### 6.11.6 Shower over bath

- In accordance with E3/AS; Either the bath rim must be recessed into the wall framing, or the shower lining must be packed out to suit the rim. A bath mould or flashing shall not be used for showers over baths. Refer to Figures 17 and 17a as mandatory for shower over bath detail.

### 6.11.7 Maintaining a silicone joint

- Never wipe sealant with an ungloved finger.
- The tool used to finish the sealant surface must be free of saliva.
- Mould can grow in wet or steamy areas if attention is not paid to adequate ventilation.

### 6.11.8 Silicone usage

The amount of silicone required depends on the application, gap width and type. As a "rule of thumb", 5 x 2.4m long joints can be achieved from one 300ml tube of silicone sealant (approximately 12m/tube).

Figure 17. Typical bath edge installation Seratone®

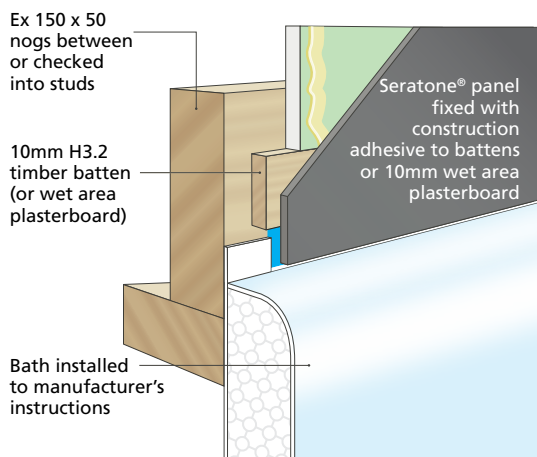

Figure 17a.

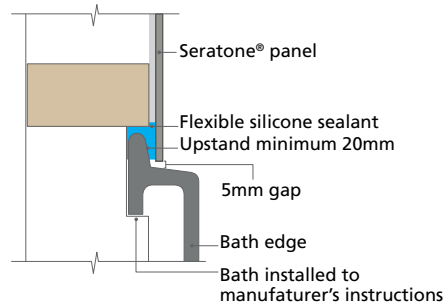
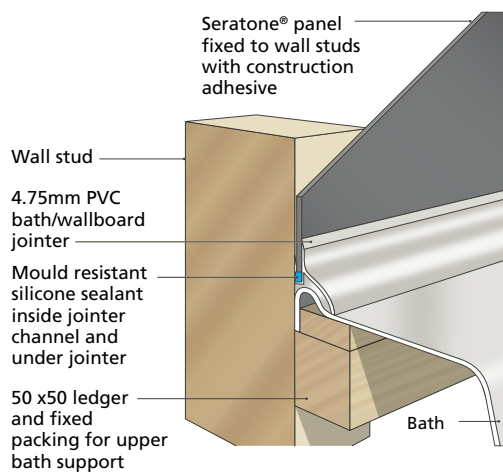

Figure 18. Mould edge installations for Seratone®



### 6.11.9 Finishing Seratone® against vinyl flooring

- Use battens to create a gap behind the Seratone® panel. It is recommended to step the back of the Seratone® panel out 10mm minimum from the face of the vinyl and hang the bottom of the Seratone® panel sheet 10 - 35mm down from the batten, where water runs over the face of the sheet (refer to Figures 19 & 19b).
- An alternative in dry areas (outside shower cubicle) a standard H jointer can be used (refer figure 20).

Figure 19.  
Finishing Seratone® against coved vinyl

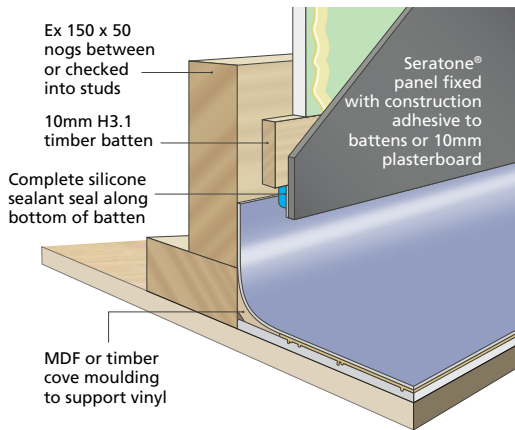

Figure 19b.

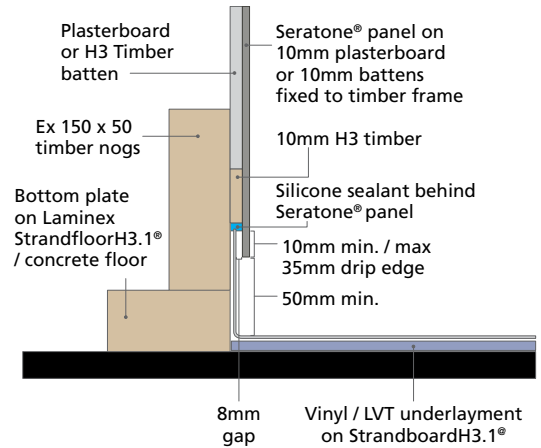

Figure 20.  
Coved flooring using divisional H jointer  
(for use outside the shower cubicle)

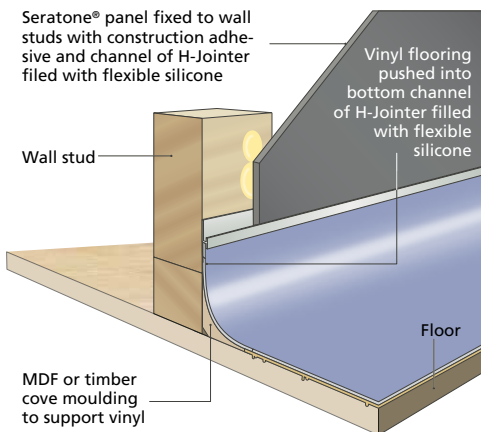
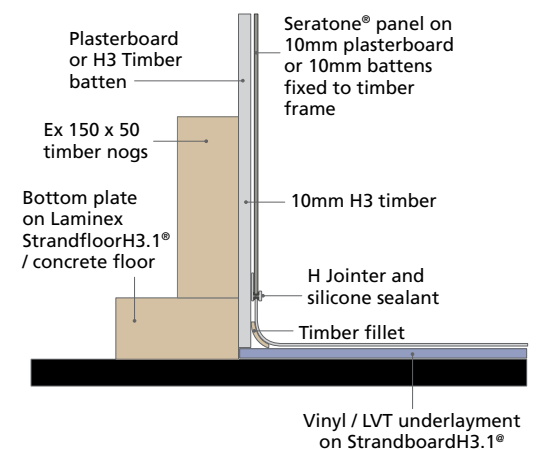

Figure 20b.



#### Note

Horizontal channelled jointers should not be used in situations where water runs over the sheet face. Contact Laminex New Zealand® for further advice.



## 6.12 Details for Seratone® AQUA tile pattern alignment

Planning, cutting of sheets and orientating alternative sheets 180 degrees is required to maximise sheet utilisation and pattern alignment for continuous runs of Seratone® AQUA Herringbone tile (3 or more sheets side by side).

This means there will be two different size sheets, with all odd numbered sheets being one size and all even numbered sheets approximately 50mm wider than odd numbered sheets. Averaging approximately 88% sheet utilisation over two 1200 wide sheets, or an average of 12% wastage over two sheets.

### IMPORTANT

It is possible the product label will not be in the same corner on every sheet, (i.e. not always bottom L/H corner). Refer to the diagrams that show the pattern on the top and bottom left and right corners.

Figure 21. Top left corner

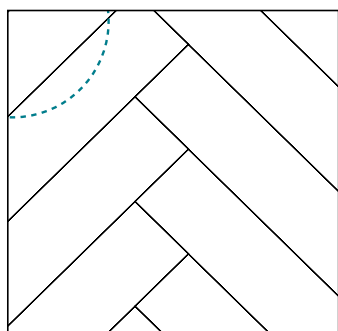

Figure 22. Top right corner

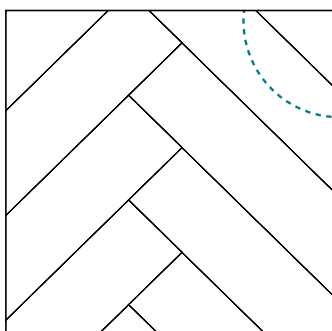

Figure 23. Bottom left corner

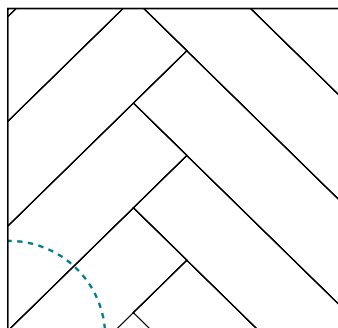
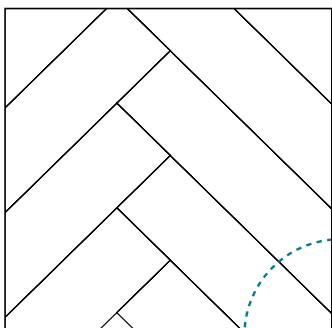

Figure 24. Bottom right corner



(Triangle larger than R/H corner)

(Triangle smaller than L/H corner)

- Installation of first sheet is from left to right. It is possible to work from the right to left by orientating and cutting sheets to the widths as detailed.
- The last sheet to finish the run can be any width up to 1200mm (i.e. the last sheet may be 1150mm to finish run).

It is recommended to sort and mark the sheets, so the reference point is identified on each sheet and they are orientated the way they will be installed. This will make marking out, measuring and cutting easier to follow. Once the first and second sheets have been marked out and cut, this repeats for the third and fourth sheets, fifth and sixth sheets etc. until the end of run.

Figure 25. Sheets before site cut

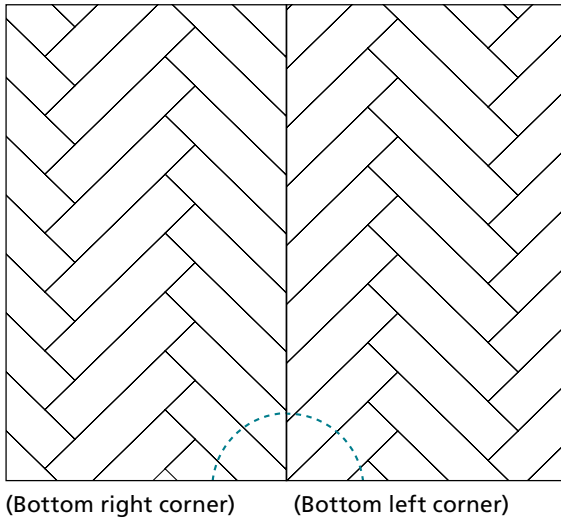

Odd numbered sheets (1, 3, 5 etc.), will be oriented with the factory vertical cut edge on the left-hand side, the sheet will be cut to 1040mm wide (13% wastage).

- The vertical right edge will be a site cut (refer to Figure 26).

Figure 26. Seratone® AQUA Herringbone tile sheet 1 (odd number) – site cut

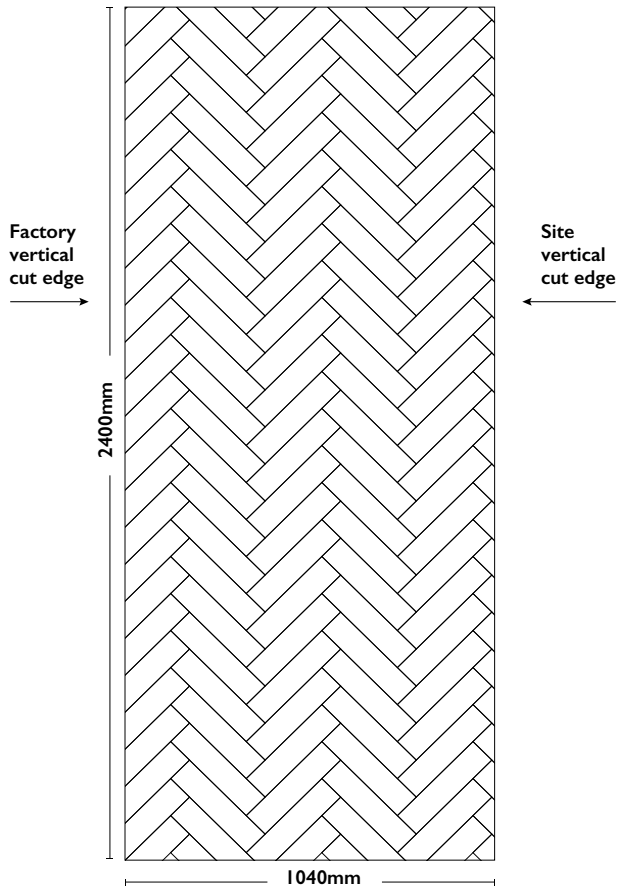

Even number sheets (2, 4, 6 etc.), will be orientated 180 degrees to the odd number sheets (upside down), the even numbered sheets will be cut to 1090mm (10% wastage).

- After the sheet is rotated 180°, the vertical left edge will be a factory edge, the right edge will be site cut (refer to Figure 27).

Figure 27. Seratone® AQUA Herringbone tile sheet 2 (even number) site cut and rotated 180 degrees

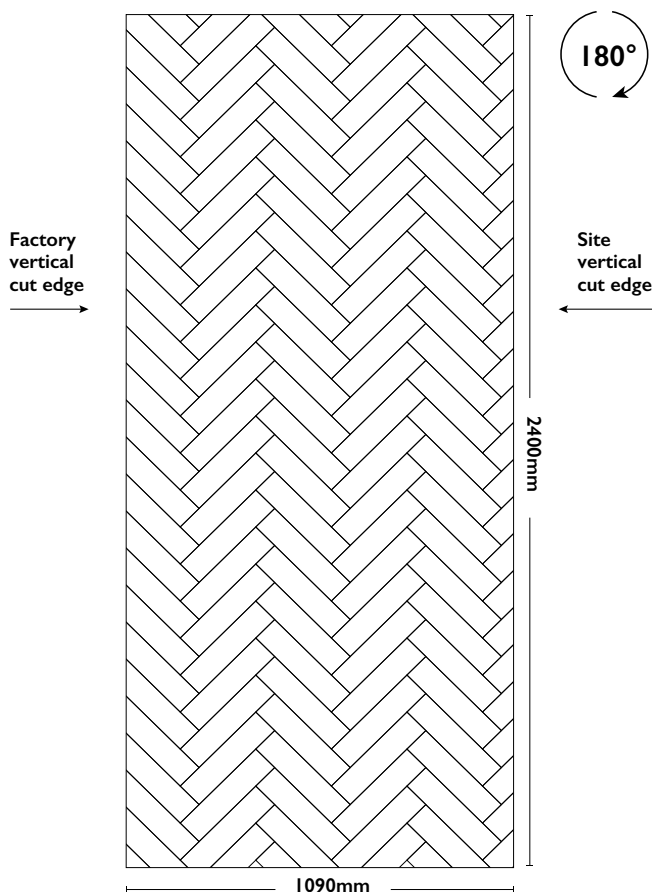

A margin of +/- 2mm should be allowed to avoid grout line / tile alignment creep at the sheet joins. Using colour matched Seratone® aluminium jointers should result in any small variance not being noticeable.

#### Silicone Joins

Tile creep may be more noticeable when using silicone joins. Accurate alignment before cutting is required.

When cutting the sheets to the widths as given, the length of the "tile" at the join may vary slightly (between 5-10mm), from the factory size "tiles" in the centre of the sheets. This is not considered to be noticeable and doesn't detract from the Herringbone tile effect.

Figure 28. Seratone® AQUA Herringbone tile sheets aligned

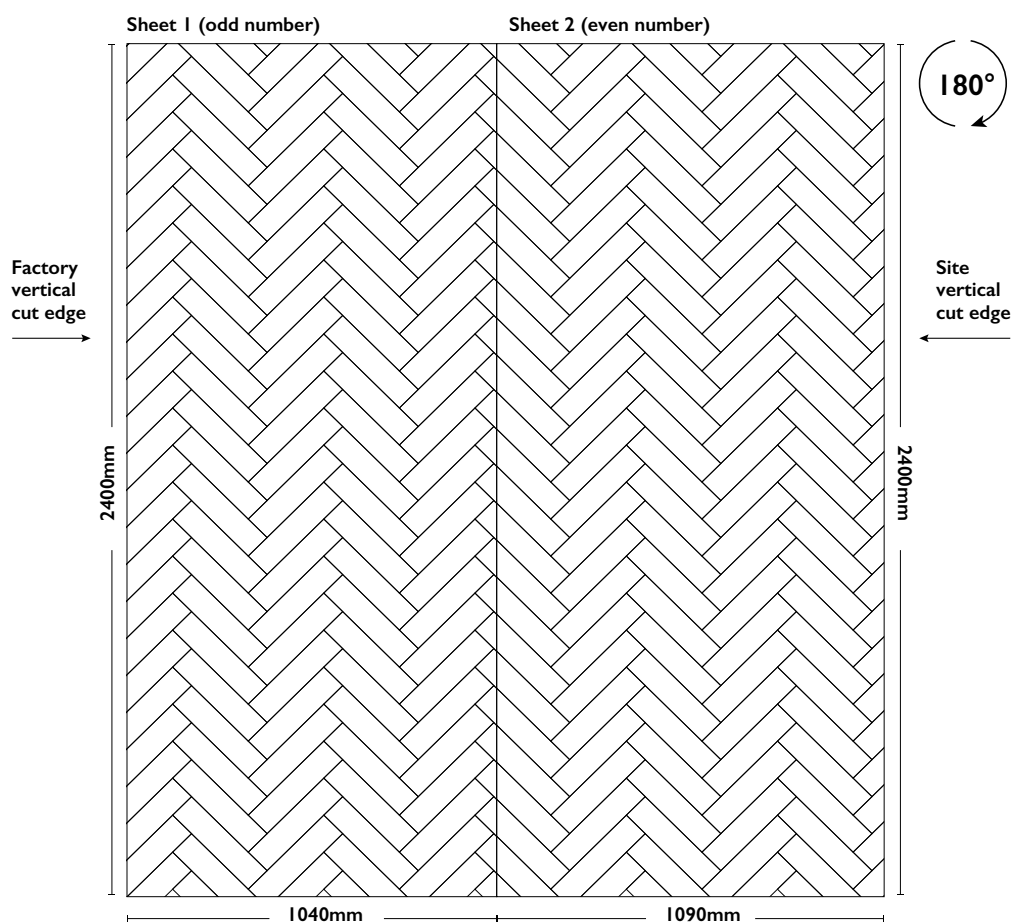

If variation in the tile length at sheet joins is a concern, then cutting sheets is required as below:

- Some minor cutting off the bottom of the first & odd numbered sheets maybe required (approximately 7-10mm).
- Sheets will now have a maximum height of 2390mm.
- If a height less than 2390mm is desired, then cut either top or bottom of sheets after alignment of pattern to desired.

# 7 Health and safety

Health and safety precautions must be taken when working with Seratone® products. Storage areas containing large quantities of Seratone® panels must be adequately ventilated.

Work areas must be well ventilated and kept clean. Sawing and machining equipment must be fitted with dust extractors to ensure that dust levels are kept within standards laid down by Worksafe New Zealand. If not, a dust mask conforming to AS/NZS 1715 and AS/NZS 1716 and eye protection conforming to AS/NZS 1337.1 must be worn.

Offcuts, shavings and dust must be disposed of in a manner that avoids the generation of dust and in accordance with the requirements of local waste authorities.

For further information and to download Safety Data Sheets (SDS) and all other technical documents, visit [laminex.co.nz](http://laminex.co.nz).

## 7.1 Dos and don'ts

### DO

- At design stage, take care that the chosen colour is suitable for the lighting situation. Lighter colours are more tolerant of harsh lighting environments.
- Transport and store sheets flat and clear of ground.
- Pre-condition sheets (separate the individual sheets and flat stack for at least 48 hours in the room to be installed (see "moisture content" on page 9).
- Measure rooms and plan the joint positions.
- Check timber framing is dry, clean and dust free.
- Provide a minimum 5mm gap at the floor and ceiling line to accommodate movement.
- Test cut, for chipping.
- Use recommended sealant, adhesive, promoter, cleaner and tape (see page 14).
- Follow adhesive and silicone manufacturer's instructions.
- Use silicone sealant in internal corners in wet areas.
- Use silicone joints when forming horizontal joints where water will run down the face of the sheet.
- Check panels have the same batch number.
- Provide a minimum 6mm gap at the floor line to accommodate movement.
- Use continuous beads of adhesive on framing or existing linings. This reduces internal panel tension, that may lead to distortion on the front of the panel.
- Use a continuous bead of silicone in all jointers and behind all fittings in wet areas. Fill the jointer 1/3 with silicone when installing Seratone® panels in showers.

**DON'T** 

- Store sheets in areas prone to damage or exposed to weather or direct sunlight.
- Store the Seratone® panels sheets upright.
- Install in saunas or steam rooms (see “moisture content” on page 9).
- Directly bond to masonry or concrete (use dry timber or steel battens).
- Fix sheets over wet or poorly prepared frames.
- Force sheets into position – always allow edge clearance.
- Nail Seratone® panels sheets – this destroys the surface.
- Use blobs of adhesive to adhere sheet to walls.
- Use an ungloved finger to apply silicone, as bacteria will encourage mould growth.
- Use abrasive cleaners or solvents on the Seratone® panels surface.
- Mix batch numbers where colour matching sheets is desired.
- Use Seratone® to form horizontal surfaces (flat) especially where water will be present.
- Apply high tack masking tapes to surface (only use low tack products).

# 8 Technical support

## 8.1 Technical support

Not all use options and Technical Information can be described in this document. Additional end use and specifying information is available as a complimentary service.

The information contained in this Technical Installation Manual must not be reproduced or published in whole or part without the prior consent of Laminex New Zealand®. Laminex New Zealand® reserves the right to revise without notice any information contained in this document.

For further information, please visit [laminex.co.nz](http://laminex.co.nz) or contact Laminex New Zealand® on 0800 303 606.

# 9 Product warranty

## 9.1 Seratone® warranty

Laminex New Zealand® (a division of Fletcher Building Products Limited) (“Distributor”) confirms the terms and conditions of the Seratone® 15 Year Limited Warranty as set out in this document (the “Warranty”) in respect of the Seratone® supplied by the Distributor to you.

Subject to the conditions and limitations set out in this warranty, when stored, handled, installed and maintained in accordance with the Seratone® Technical Information that is current at the time of installation, Seratone® will meet the durability requirements of the New Zealand Building Code (NZBC) B2/AS1 and has a serviceable life of 15 years in wet areas and 5 years in all other internal applications.

If you have any questions, or in the unlikely event of a problem with Seratone®, please contact Laminex New Zealand® Customer Services on 0800 303 606

The most current Seratone® Technical Information is available online at [laminex.co.nz](http://laminex.co.nz)

### Terms and conditions

1. This warranty applies to the full range of Seratone® AQUA and Seratone® AQUA PLUS™ products supplied by Laminex New Zealand® (subject to any exceptions noted in Laminex New Zealand® literature) and used in interior applications subject to the terms and conditions of this warranty.
2. This warranty does not cover damage caused by:
  - a) Any act of God, any natural occurrence or any other circumstance beyond Laminex New Zealand’s control; or
  - b) Application design or installation in any respect, or the failure to follow any procedures or guidance (if any) that may be issued in Seratone® Technical Information made available by Laminex New Zealand®, or best industry practices for the fabrication and installation of Seratone® AQUA and Seratone® AQUA PLUS™ products (including, but not limited to, incorrect substrate preparation, or use of incorrect sealant, adhesive, promoter, cleaner and tape or incorrect application of sealant, adhesive, promoter, cleaner and tape); or
  - c) Failure to follow the maintenance and cleaning guide for Seratone® panels, as set out in Seratone® Technical Information made available by Laminex New Zealand® ; or
  - d) Physical abuse, misuse, accidents, impacts, incorrect handling, wear and tear, improper maintenance; or
  - e) Failure of any adhesive, grout, caulk, sealant or other accessory, or failure of any caulked or filled joint or seams; or
  - f) Events directly or indirectly attributable to the underlying substrate or structure, including building framing, building substructure or anchoring systems, or failure of any substrate or application design flaws, overloading of substrate, building movement, or any consequential or indirect loss or damage caused or contributed to by any defect; or



- g) The product being used in applications not expressly recommended in the Seratone® Technical Information made available by Laminex New Zealand®; or
  - h) Any Seratone® product that is not installed by an appropriately trained and skilled person; or
  - i) Variation in colour, pattern, shade of the material against the sample material, displays and/or printed illustrations; or
  - j) Any exterior use or application;
  - k) Where the defect is trivial or insubstantial; or
  - l) Where, as at the date of notification of the defect to Laminex New Zealand®, the type or colour of the alleged defective product no longer forms part of Laminex New Zealand's standard stock range and the person complaining of the defect does not agree to the supply of a replacement which is as close a type or colour match as is possible from Laminex New Zealand's then prevailing stock range.
3. Subject to the terms of this warranty, this warranty applies only to Seratone® products:
- a) Which have not been moved from their original place of installation;
  - b) Which have been used in an internal application;
  - c) Which have been fabricated or installed by a business which has been supplied with such Seratone® products by Laminex New Zealand® directly, or indirectly through Laminex New Zealand's re-seller network;
  - d) Which have been fabricated, installed, maintained, cleaned, used and protected in the manner set out in Seratone® Technical Information made available by Laminex New Zealand® concerning those products; and
  - e) Where Laminex New Zealand® has been notified of the defect within seven days of the first person to become aware of it, or within seven days of such time as the defect ought reasonably to have been identified (whichever is earlier).
4. Subject to the terms of this warranty, Laminex New Zealand® will, at its option, repair or replace the product free of charge. A replacement product from Laminex New Zealand® may not be available in the same colour or shape as the original Seratone® product covered by this warranty. If a replacement product from Laminex New Zealand® of the same colour or shape is not reasonably available, Laminex New Zealand® reserves the right to provide a replacement product of as close a shape and colour match as is reasonably possible from Laminex New Zealand's then prevailing stock range in satisfaction of its obligations under this warranty.
5. This warranty does not cover costs or losses relating to:
- a) Removal of products or system.
  - b) Installation of new substitute products or system.
  - c) Restoration work.
  - d) Any other direct or indirect, or consequential costs, losses, expenses or loss of earnings.

6. Other than as provided in these terms, Laminex New Zealand® will have no liability to a claimant (whether in statute, contract, tort, or otherwise at law or in equity) in respect of any defects in the product or for any loss, damage, costs or expenses caused by the product or defects in the product, provided that nothing in this paragraph 6 or otherwise in these terms excludes or modifies any legal rights you may have, including rights under the Consumer Guarantees Act 1993 (as applicable). This warranty should therefore not be read as exhaustive statement of the rights of the original end user or any other person.
7. This warranty is not transferable or assignable.

**Laminex New Zealand® Customer Services**

**Contact Number** | 0800 303 606

**Postal Address** | PO Box 12270, Auckland 1642, New Zealand

**Website** | [laminex.co.nz](http://laminex.co.nz)



VISIT US

[laminex.co.nz](https://laminex.co.nz)

CALL US

0800 303 606

J011393 08.24